

### Introduction

The STM32H747I-DISCO Discovery kit is a complete demonstration and development platform for the STMicroelectronics Arm<sup>®</sup> Cortex<sup>®</sup>-M7 and -M4 dual-core-based STM32H747XIH6 microcontroller with four I<sup>2</sup>C, six SPIs with two multiplexed full-duplex I<sup>2</sup>S interfaces, SDIO3.0, SDIO2.0, four USARTs, four UARTs, two FD-CANs, three 16-bit ADCs, two 12-bit DACs, four SAIs, USB HS OTG and USB FS OTG, Ethernet MAC, FMC interface, MIPI DSI<sup>®</sup> host controller, Quad-SPI interface, and JTAG and ETM debugging support.

The STM32H747I-DISCO Discovery kit, shown in [Figure 1](#) and [Figure 2](#), is used as a reference design for user application development before porting to the final product.

STM32H747I-DISC1, presented in [Figure 3](#), is the subset of STM32H747I-DISCO without the LCD display module.

The full range of hardware features available on the board helps users improve application development by an evaluation of all the peripherals (USB OTG2 HS, Ethernet, microSD<sup>™</sup> card, SAI Audio DAC stereo with audio jack input and output, MEMS digital microphone, SDRAM, Quad-SPI flash memory, DCMI connector, MIPI DSI<sup>®</sup> interface, and others). ARDUINO<sup>®</sup> Uno V3 and Pmod<sup>™</sup>/STMod+ connectors provide easy connection to extension shields or daughterboards for specific applications.

An STLINK-V3E is integrated into the board, as the embedded in-circuit debugger and programmer for the STM32 MCU and the USB Virtual COM port bridge.

Figure 1. STM32H747I-DISCO top view



Figure 2. STM32H747I-DISCO bottom view

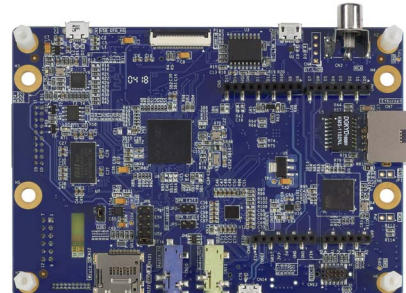
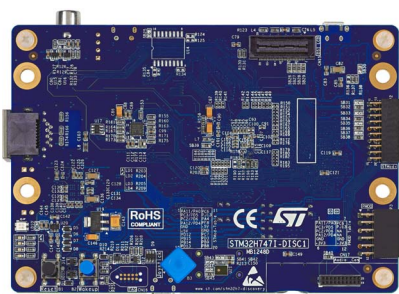


Figure 3. STM32H747I-DISC1 top view



Pictures are not contractual.  
PCB colors may differ.

# Contents

<b>1</b>	<b>Features</b> .....	<b>7</b>
<b>2</b>	<b>Ordering information</b> .....	<b>8</b>
	2.1 Codification .....	8
<b>3</b>	<b>Development environment</b> .....	<b>9</b>
	3.1 System requirements .....	9
	3.2 Development toolchains .....	9
<b>4</b>	<b>Delivery recommendations</b> .....	<b>9</b>
<b>5</b>	<b>Hardware layout and configuration</b> .....	<b>10</b>
	5.1 STLINK-V3E .....	14
	5.1.1 Drivers and firmware upgrade .....	14
	5.2 Power supply .....	14
	5.2.1 Supplying the board through STLINK-V3E USB port .....	15
	5.2.2 Using STLINK-V3E along with powering through external power .....	15
	5.2.3 SMPS/LDO power supply .....	16
	5.3 Clock references .....	18
	5.4 Reset Source .....	18
	5.5 Audio .....	18
	5.5.1 Digital microphone .....	19
	5.6 USB OTG HS port .....	19
	5.6.1 STM32H747I-DISCO as USB device .....	19
	5.6.2 STM32H747I-DISCO as USB host .....	20
	5.7 Ethernet .....	20
	5.8 SDRAM .....	21
	5.9 Quad-SPI flash memory .....	21
	5.10 Virtual COM port .....	21
	5.11 User LEDs .....	21
	5.12 Physical input devices .....	21
<b>6</b>	<b>Connectors</b> .....	<b>22</b>

6.1	USB OTG HS Micro-AB connector CN1	22
6.2	STLINK-V3E USB Micro-B connector CN2	23
6.3	SPDIF input RCA connector CN3	23
6.4	STLINK-V3E MCU programming header CN4	23
6.5	ARDUINO <sup>®</sup> Uno V3 connectors CN5, CN6, CN8 and CN9	24
6.6	Ethernet RJ45 connector CN7	25
6.7	Audio blue jack (Line In) connector CN10	25
6.8	Audio green jack (Line Out) connector CN11	26
6.9	microSD <sup>™</sup> card connector CN12	27
6.10	STDC14 connector CN13	28
6.11	External 5 V USB Micro-B connector CN14	29
6.12	DSI <sup>®</sup> LCD connector CN15 (MIPI <sup>®</sup> )	29
6.13	TAG connector CN16	31
6.14	Audio connector CN17	31
6.15	Camera module connector P1	32
6.16	STMod+ connector P2	33
6.17	Pmod <sup>™</sup> connector P3	34
<b>7</b>	<b>STM32H747I-DISCO I/O assignment</b>	<b>35</b>
<b>8</b>	<b>STM32H747I-DISCO Discovery kit information</b>	<b>43</b>
8.1	Product marking	43
8.2	STM32H747I-DISCO product history	44
8.3	Board revision history	46
<b>9</b>	<b>Federal Communications Commission (FCC) and ISED Canada Compliance Statements</b>	<b>47</b>
9.1	FCC Compliance Statement	47
9.1.1	Part 15.19	47
9.1.2	Part 15.21	47
9.1.3	Part 15.105	47
9.2	ISED Compliance Statement	47
<b>10</b>	<b>CE conformity</b>	<b>48</b>
10.1	Warning	48

---

**Appendix A STMod+ GPIO sharing and multiplexing . . . . . 49**

**Revision history . . . . . 50**

## List of tables

Table 1.	List of available products	8
Table 2.	Codification explanation	8
Table 3.	Power-supply related jumper and solder bridge settings	17
Table 4.	Digital microphone-related jumper settings	19
Table 5.	Ethernet related solder bridge and resistor settings	20
Table 6.	USB OTG HS Micro-AB connector CN1	22
Table 7.	USB Micro-B connector CN2	23
Table 8.	SPDIF input RCA connector CN3	23
Table 9.	STLINK-V3E MCU programming header CN4	23
Table 10.	ARDUINO® Uno V3 compatible connectors	24
Table 11.	USB Micro-B connector CN2	25
Table 12.	Audio jack connector CN11 (on board)	26
Table 13.	microSD™ connector CN12	27
Table 14.	STDC14 debugging connector CN13	28
Table 15.	USB Micro-B connector CN14	29
Table 16.	DSI® LCD module connector CN15	30
Table 17.	TAG connector CN16	31
Table 18.	Audio connector CN17	31
Table 19.	Camera module connector P1	32
Table 20.	STMod+ connector P2	33
Table 21.	Pmod™ connector P3	34
Table 22.	STM32H747I-DISCO I/O assignment	35
Table 23.	Product history	44
Table 24.	Board revision history	46
Table 25.	STMod+ GPIO sharing and multiplexing	49
Table 26.	Document revision history	50

## List of figures

Figure 1.	STM32H747I-DISCO top view . . . . .	1
Figure 2.	STM32H747I-DISCO bottom view . . . . .	1
Figure 3.	STM32H747I-DISCO top view. . . . .	1
Figure 4.	STM32H747I-DISCO hardware block diagram. . . . .	10
Figure 5.	STM32H747I-DISCO board layout (top view). . . . .	11
Figure 6.	STM32H747I-DISCO board layout (bottom view). . . . .	12
Figure 7.	STM32H747I-DISCO board mechanical dimensions (top view). . . . .	13
Figure 8.	USB OTG HS Micro-AB connector CN1. . . . .	22
Figure 9.	USB Micro-B connector CN2 . . . . .	23
Figure 10.	Ethernet RJ45 connector CN7 (front view) . . . . .	25
Figure 11.	Stereo headset with microphone jack CN11. . . . .	26
Figure 12.	microSD™ connector CN12 . . . . .	27
Figure 13.	STDC14 debugging connector CN13 (top view). . . . .	28
Figure 14.	USB Micro-B connector CN14 . . . . .	29
Figure 15.	DSI® LCD module connector CN15 . . . . .	29
Figure 16.	TAG connector CN16 . . . . .	31
Figure 17.	Camera module connector P1 (front view) . . . . .	32
Figure 18.	STMod+ connector P2 . . . . .	33
Figure 19.	Pmod™ connector P3. . . . .	34

# 1 Features

- STM32H747XIH6 Arm<sup>®(a)</sup> Cortex<sup>®</sup> core-based microcontroller with 2 Mbytes of flash memory and 1 Mbyte of RAM in TFBGA240 + 25 package
- 4" capacitive touch LCD display module with MIPI DSI<sup>®</sup> interface (STM32H747I-DISCO order code only)
- Ethernet compliant with IEEE802.3-2002
- USB OTG HS
- SAI audio codec
- ST-MEMS digital microphone
- 2 x 512-Mbit Quad-SPI NOR flash memory
- 256-Mbit SDRAM
- 4 color user LEDs
- 1 user and reset push-button
- 4-direction joystick with selection button
- Fan-out daughterboard
- Board connectors:
  - Camera (8-bit)
  - USB with Micro-AB
  - Ethernet RJ45
  - SPDIF RCA input and output
  - Stereo headset jack including analog microphone input
  - Audio jack for external speakers
  - microSD<sup>™</sup> card
  - TAG-Connect 10-pin footprint
  - Arm<sup>®</sup> Cortex<sup>®</sup> 10-pin 1.27 mm-pitch debug connector over STDC14 footprint
  - ARDUINO<sup>®</sup> Uno V3 expansion
  - Pmod<sup>™</sup> expansion supported by Type 2A and Type 4A
  - STMod+ expansion
  - Audio daughterboard expansion
- Flexible power-supply options: ST-LINK USB VBUS, USB OTG HS connector, or external sources
- On-board STLINK-V3E debugger/programmer with USB re-enumeration capability: mass storage, Virtual COM port and debug port
- Comprehensive free software libraries and examples available with the STM32Cube MCU Package
- Support of a wide choice of Integrated Development Environments (IDEs) including IAR Embedded Workbench<sup>®</sup>, MDK-ARM, and STM32CubeIDE



---

a. Arm is a registered trademark of Arm Limited (or its subsidiaries) in the US and/or elsewhere.

## 2 Ordering information

To order the STM32H747I-DISCO or STM32H747I-DISC1 Discovery kit, refer to [Table 1](#). Additional information is available from the datasheet and reference manual of the target STM32.

**Table 1. List of available products**

Order code	Board reference	Target STM32	Differentiating feature
STM32H747I-DISCO	<ul style="list-style-type: none"> <li>– MB1166<sup>(1)</sup></li> <li>– MB1248<sup>(2)</sup></li> <li>– MB1280<sup>(3)</sup></li> </ul>	STM32H747XIH6	– With LCD module
STM32H747I-DISC1	<ul style="list-style-type: none"> <li>– MB1248<sup>(2)</sup></li> <li>– MB1280<sup>(3)</sup></li> </ul>	STM32H747XIH6	– No LCD module

1. LCD daughterboard.
2. Main board.
3. STMod+ fan-out board

### 2.1 Codification

The meaning of the codification is explained in [Table 2](#).

**Table 2. Codification explanation**

STM32H7XXY-DISCZ	Description	Example: STM32H747I-DISCO
STM32H7	MCU series in STM32 High Performance MCUs	STM32H7 series
XX	MCU line in the series	STM32H747 line
Y	STM32 flash memory size: – I: 2 Mbytes	STM32H747XI MCU with 2 Mbytes of flash memory
DISCZ	Toolkit configuration: – DISCO: Discovery kit with LCD module – DISC1: Discovery kit without LCD module	Discovery kit with LCD module



## 3 Development environment

### 3.1 System requirements

- Multi.OS support: Windows<sup>®(a)</sup> 10, Linux<sup>®(b)</sup> 64-bit, or macOS<sup>®(c)</sup>
- USB Type-A or USB Type-C<sup>®</sup> to Micro-B cable

### 3.2 Development toolchains

- IAR Systems<sup>®</sup> - IAR Embedded Workbench<sup>®(d)</sup>
- Keil<sup>®</sup> - MDK-ARM<sup>(d)</sup>
- STMicroelectronics - STM32CubeIDE

## 4 Delivery recommendations

Before the first use, make sure that no damage occurred to the board during shipment and no socketed components are not firmly fixed in their sockets or loose in the plastic bag.

In particular, pay attention to the following component:

- DSI<sup>®</sup> display MB1166 daughterboard in the CN15 connector if requested

For product information related to the STM32H747XIH6 microcontroller, visit the [www.st.com](http://www.st.com) website.

- 
- a. Windows is a trademark of the Microsoft group of companies.
  - b. Linux<sup>®</sup> is a registered trademark of Linus Torvalds.
  - c. macOS<sup>®</sup> is a trademark of Apple Inc. registered in the U.S. and other countries.
  - d. On Windows<sup>®</sup> only.

## 5 Hardware layout and configuration

The STM32H747I-DISCO Discovery kit is designed around the STM32H747XIH6 target microcontroller in TFBGA 240+25-pin package. *Figure 4* illustrates the connections of the STM32H747XIH6 with the peripheral components. *Figure 5* and *Figure 6* show the locations of the main components on the Discovery kit.

Figure 4. STM32H747I-DISCO hardware block diagram

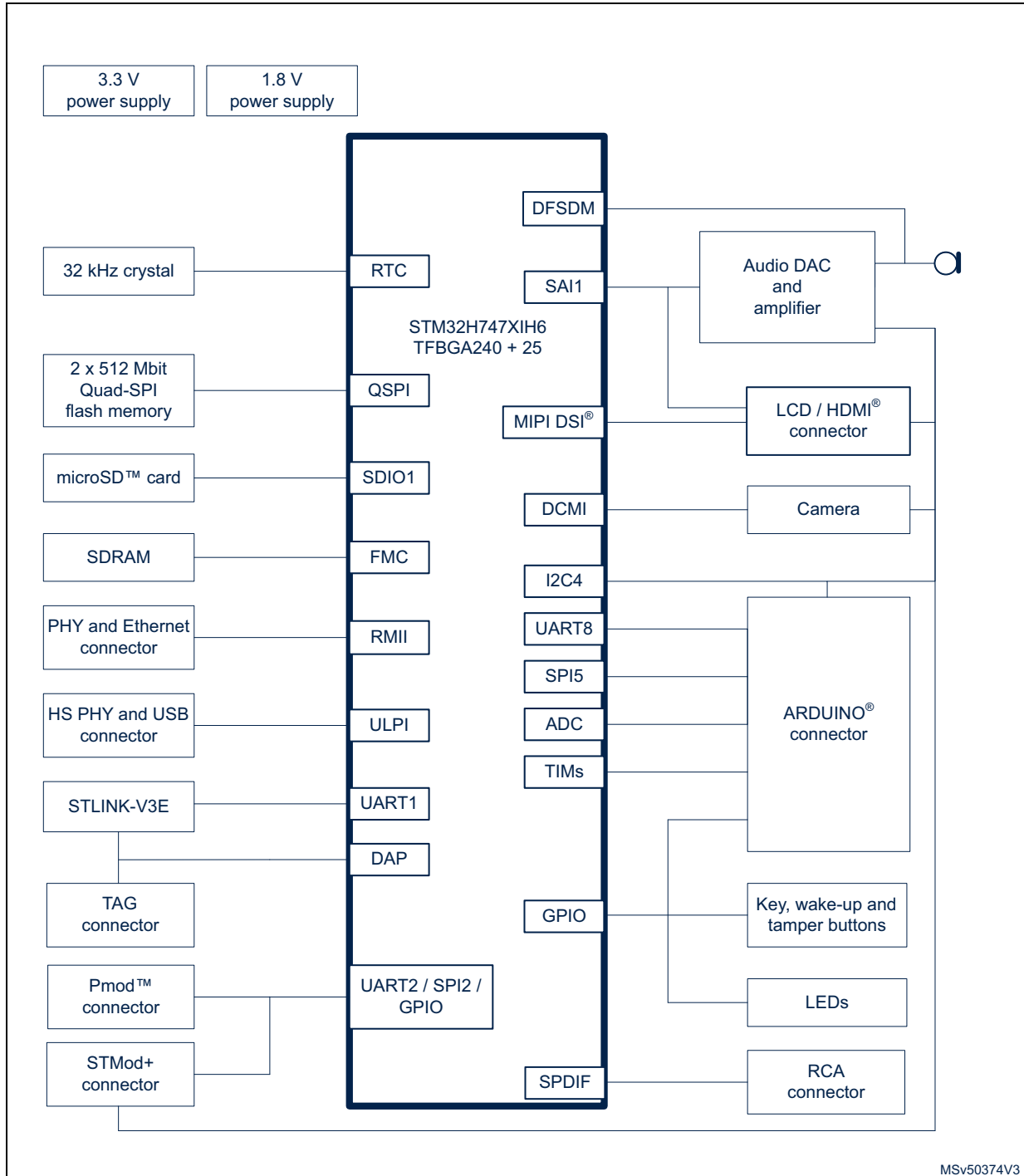


Figure 5. STM32H747I-DISCO board layout (top view)

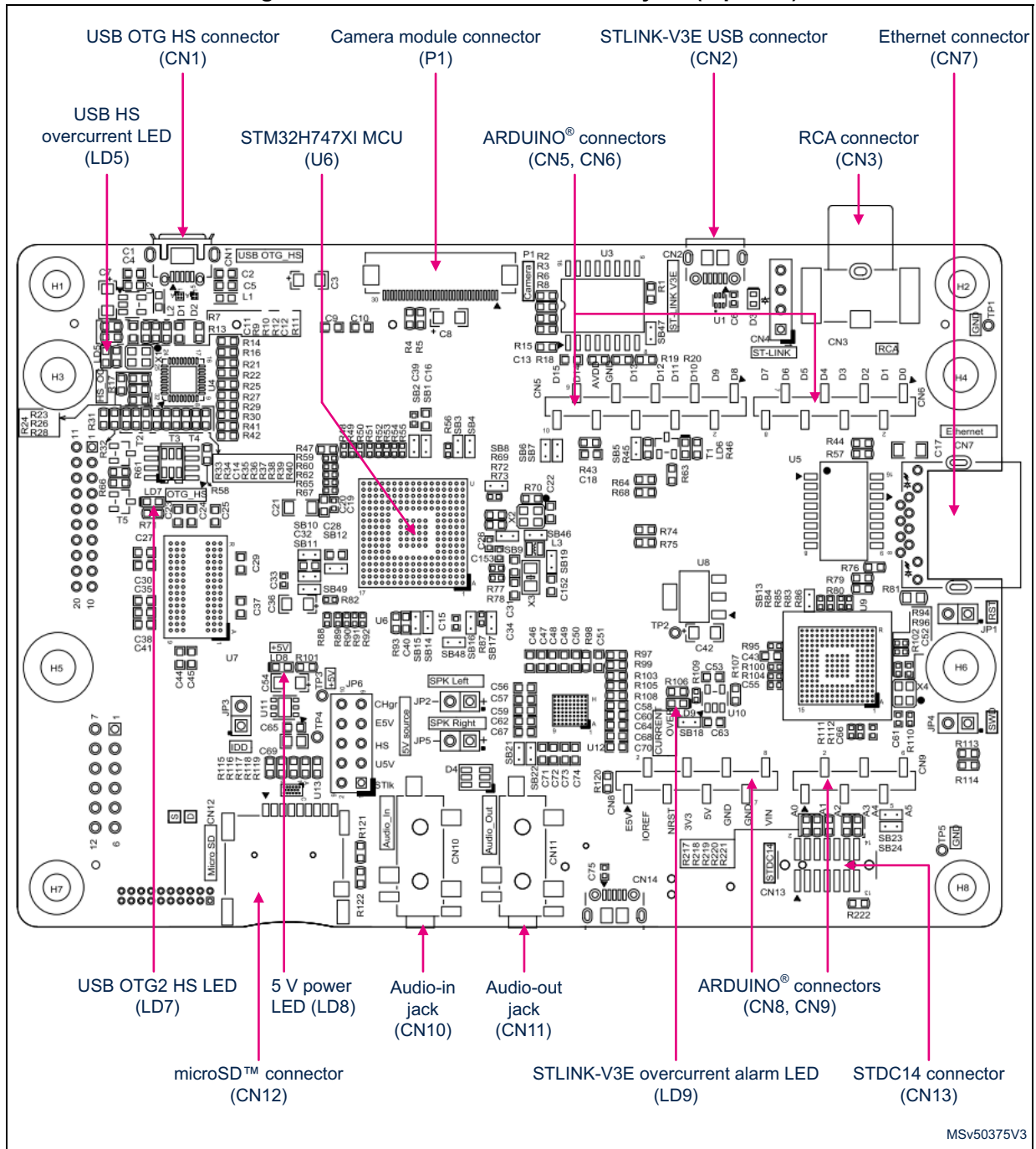


Figure 6. STM32H747I-DISCO board layout (bottom view)

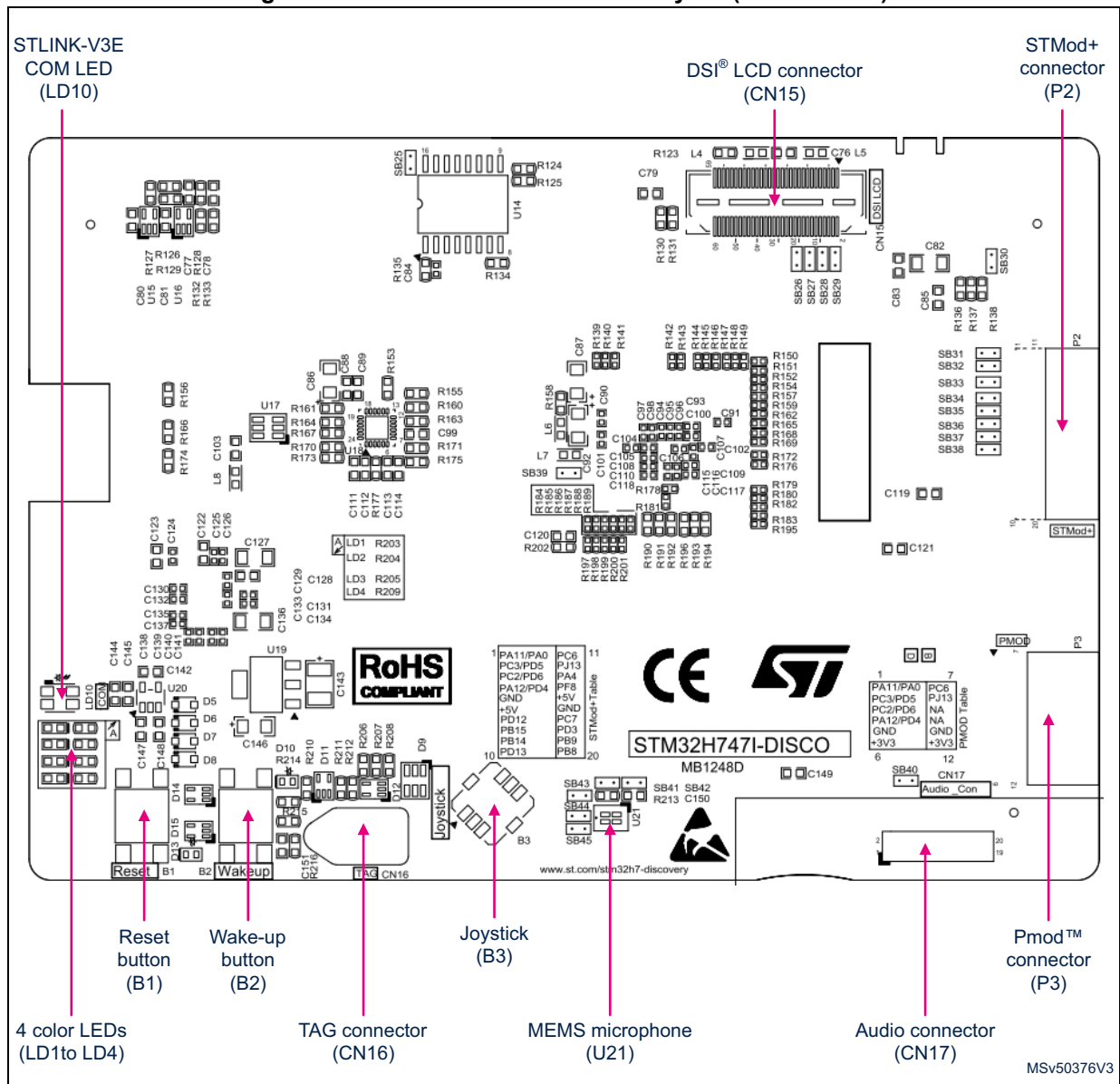
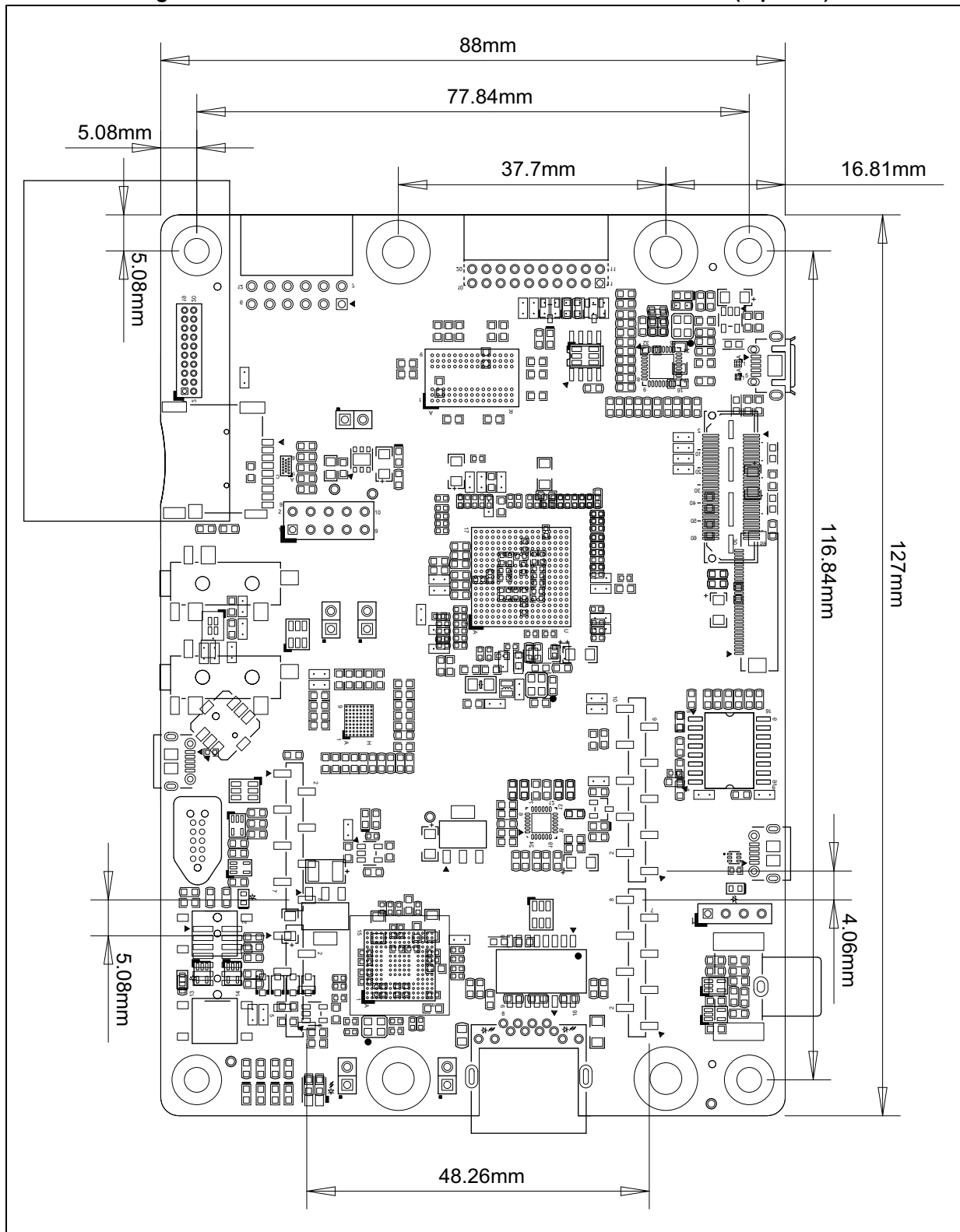


Figure 7 provides the mechanical dimensions of the STM32H747I-DISCO Discovery board.

Figure 7. STM32H747I-DISCO board mechanical dimensions (top view)



## 5.1 STLINK-V3E

The STLINK-V3E facility for the debug and programming of the STM32H747XIH6 is integrated on the STM32H747I-DISCO Discovery kit. It supports the following features:

- Self-powered through a USB connector (Micro-B)
- USB 2.0 high-speed compatible interface
- Direct firmware update support (DFU)
- SWD and serial wire viewer (SWV) communication support
- Drag-and-drop flash memory programming
- Two color LEDs: communication and power

USB connector CN2 can be used to power the STM32H747I-DISCO regardless of the STLINK-V3E facility used for debugging or programming the STM32H747XIH6. This holds also when the STLINK-V3E stand-alone tool is connected to connector CN13 or CN16 and used for debugging or programming the STM32H747XIH6. [Section 5.2: Power supply](#) provides more detail about powering the STM32H747I-DISCO.

Refer to [www.st.com](http://www.st.com) for details about STLINK-V3E.

### 5.1.1 Drivers and firmware upgrade

The STLINK-V3E requires drivers to be installed on Windows<sup>®</sup>. It embeds firmware that needs regular update in order to benefit from new functionality or corrections. Refer to the *Overview of ST-LINK derivatives* technical note (TN1235) for details.

## 5.2 Power supply

The STM32H747I-DISCO Discovery kit is designed to be powered from a 5 V DC power source. One of the following five 5 V DC power inputs can be used, upon appropriate board configuration:

- Micro-B USB receptacle CN2 of STLINK-V3E with enumeration:  
Up to 500 mA can be supplied to the board (JP6 jumper setting on STlk on silkscreen). Offers the enumeration feature described in [Section 5.2.1](#).
- Micro-B USB receptacle CN2 of STLINK-V3E without enumeration:  
Up to 500 mA can be supplied to the board directly without enumeration (JP6 jumper setting on CHgr on silkscreen).
- Micro-AB USB receptacle CN1 of the USB OTG HS interface:  
Marked USB\_OTG\_HS on the board (JP6 jumper setting on HS on silkscreen). Up to 500 mA can be supplied to the board in this way.
- 7-12V DC power from CN8 pin8:  
Named VIN on silkscreen, the extension connectors for ARDUINO<sup>®</sup> Uno shields (JP6 setting on external power source on silkscreen (E5V)).
- Micro-B USB receptacle CN14 for external 5V:  
Up to 500 mA can be supplied to the board (JP6 jumper setting on U5V on silkscreen).

The LD8 green LED turns on when the voltage on the power line marked as +5V is present. All supply lines required for the operation of the components on the STM32H747I-DISCO are derived from that +5V line.

[Table 3: Power-supply related jumper and solder bridge settings](#) describes the settings of all jumpers related to powering the STM32H747I-DISCO and extension board. VDD\_MCU is STM32H747XIH6 digital supply voltage line. It can be connected to a fixed 3.3 V supply.

### 5.2.1 Supplying the board through STLINK-V3E USB port

To power the STM32H747I-DISCO in this way, the USB host (a PC) gets connected to the Micro-B USB receptacle of the STM32H747I-DISCO via a USB cable. The connection event starts the USB enumeration procedure. In its initial phase, the host USB port current supply capability is limited to 100 mA. It is enough because only the STLINK-V3E part of the STM32H747I-DISCO draws power at that time: the U10 STMP2151 power switch is set to the OFF position, which isolates the rest of the STM32H747I-DISCO from the power source. In the next phase of the enumeration procedure, the host PC informs the STLINK-V3E facility of its capability to supply current up to 300 mA. If the answer is positive, the STLINK-V3E sets the U10 STMP2151 switch to the ON position to supply power to the rest of the STM32H747I-DISCO board. If the PC USB port is not capable of supplying current up to 300 mA of, CN8 pin8 (VIN) or CN14 can be used to supply the board instead.

Should a short-circuit occur on the board, the STMP2151 power switch protects the USB port of the host PC against a current demand exceeding 500 mA. In such an event, the LD9 LED lights up.

The STM32H747I-DISCO board can also be supplied from a USB power source not supporting enumeration, such as a USB charger. In this particular case, jumper JP6 must be fitted with a jumper hat as shown in [Table 3: Power-supply related jumper and solder bridge settings](#). STLINK-V3E bypasses STMP2151 power regardless of enumeration procedure result and passes the power unconditionally to the board.

The LD8 green LED turns on whenever the whole board is powered.

### 5.2.2 Using STLINK-V3E along with powering through external power

It can happen that the board requires more than 300 mA of supply current. It cannot be supplied from the host PC connected to the STLINK-V3E USB port for debugging or programming the STM32H747XIH6. In such a case, the board can be supplied through CN8 pin8 (marked VIN on the board) or CN14.

To do this, it is important to power the board before connecting it with the host PC, which requires the following sequence to be respected:

1. Set jumper JP6 in the E5V or U5V position
2. Connect the external power source to CN8 pin8 or CN14
3. Check that the green LED LD8 is turned on
4. Connect the host PC to USB connector CN2

**Caution:** In case the board demands more than 300 mA and the host PC is connected via USB before the board is powered from CN8 pin8 or CN14, there is a risk that the following events occur (listed in reverse severity order):

1. The host PC is capable of supplying 300 mA (the enumeration succeeds) but it features no over-current protection on its USB port. It is damaged due to over-current.
2. The host PC is capable of supplying 300 mA (the enumeration succeeds) and it has a built-in over-current protection on its USB port, limiting or shutting down the power out

of its USB port when the excessive current demand from STM32H747I-DISCO is detected. This causes an operating failure of STM32H747I-DISCO.

3. The host PC is not capable of supplying 300 mA (the enumeration fails). The STLINK-V3E does not supply the rest of the STM32H747I-DISCO from its USB port VBUS line.

### 5.2.3 SMPS/LDO power supply

There are two possible solutions to provide power to MCU Vcore: SMPS or LDO. Power figures in Run mode are significantly improved when Vcore logic power is supplied by the internal DC/DC converter (SMPS). The default power supply for Vcore logic is SMPS. The user need to apply some changes to switch to the LDO power supply:

- SMPS mode (default):
  - SB2, SB11, SB19, SB46, SB48 mounted
  - SB1, SB12, SB49 removed
- LDO mode:
  - SB1, SB12, SB49 mounted
  - SB2, SB11, SB19, SB46, SB48 removed

**Caution:** A deadlock occurs if the board SMPS/LDO firmware PWR configuration does not match the hardware configuration: after the reset, the ST-LINK cannot connect the target anymore.

The firmware PWR configuration must be set as follows in function `SystemClock_Config` in file `main.c`:

- If the hardware configuration is “Direct SMPS” (default configuration):  
`HAL_PWREx_ConfigSupply(PWR_DIRECT_SMPS_SUPPLY);`
- If the hardware configuration is “LDO”:  
`HAL_PWREx_ConfigSupply(PWR_LDO_SUPPLY);`

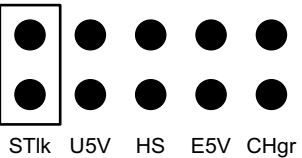
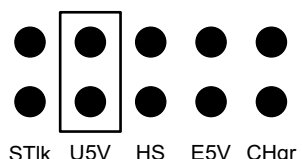
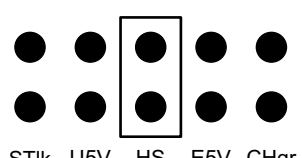
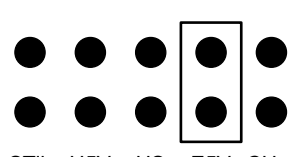
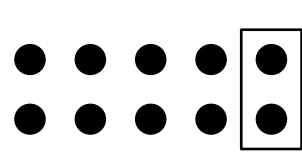
If a deadlock occurs because of a mismatch between hardware and firmware PWR settings (SMPS/LDO), the user can recover the board by applying the following procedure:

1. Power off the board.
2. Connect pin BOOT0 to  $V_{DD}$  using a wire (or short R192).  
This changes the BOOT0 pin to 1 instead of 0, thus changing the device boot address to boot address 1 and making the bootloader start in System memory. This avoids starting firmware in the user flash memory with a wrong SMPS/LDO configuration versus the hardware board configuration.
3. Power on the board and connect using STM32CubeProgrammer (STM32CubeProg).
4. Erase the user flash memory.
5. Power off the board and remove the short between BOOT0 and  $V_{DD}$ .
6. The board is recovered and can be used normally with matching firmware PWR.

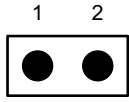



Table 3 details jumper and solder bridge settings used for the configuration of the power supply of STM32H747I-DISCO.

**Table 3. Power-supply related jumper and solder bridge settings**

Jumper / Solder bridge	Setting	Configuration
JP6 Power source selector	 <p>STIk U5V HS E5V CHgr</p>	<b>Default setting.</b> STM32H747I-DISCO is supplied through the CN2 Micro-B USB receptacle. Depend on host PC USB port's powering capability declared in the enumeration.
	 <p>STIk U5V HS E5V CHgr</p>	STM32H747I-DISCO is supplied through the CN14 Micro-B USB receptacle.
	 <p>STIk U5V HS E5V CHgr</p>	STM32H747I-DISCO is supplied through the CN1 Micro-AB USB receptacle.
	 <p>STIk U5V HS E5V CHgr</p>	STM32H747I-DISCO is supplied through the pin 8 of CN8 (marked VIN).
	 <p>STIk U5V HS E5V CHgr</p>	STM32H747I-DISCO is supplied through the CN2 Micro-B USB receptacle. Setting for powering the board through CN2 using USB charger.
SB16 V <sub>BAT</sub> connection	SB16 ON	<b>Default setting.</b> V <sub>BAT</sub> is connected to +3V3.
	SB16 OFF	V <sub>BAT</sub> is not connected to +3V3.
SB10 V <sub>DD_USB</sub> connection	SB10 ON	<b>Default setting.</b> V <sub>DD_USB</sub> (VDDUSB terminal of STM32H747XIH6) is connected to V <sub>DD_MCU</sub> .
	SB10 OFF	V <sub>DD_USB</sub> is not connected to V <sub>DD_MCU</sub> .

**Table 3. Power-supply related jumper and solder bridge settings (continued)**

Jumper / Solder bridge	Setting	Configuration
JP3 V <sub>DD_MCU</sub> connection		<b>Default setting.</b> V <sub>DD_MCU</sub> (VDD terminals of STM32H747XIH6) is connected to fixed +3.3 V.
		V <sub>DD_MCU</sub> (VDD terminals of STM32H747XIH6) is not connected to fixed +3.3 V

### 5.3 Clock references

Two clock references (X2 and X3) are available on the STM32H747I-DISCO for the STM32H747XIH6 target microcontroller. The two other clock sources (X1 and X4) are for the peripherals:

- 24 MHz oscillator X1, for USB OTG HS PHY and camera module (daughter board)
- 25 MHz oscillator X2, for main clock generator and Ethernet PHY
- 32.768 kHz crystal X3, for embedded RTC
- 25 MHz oscillator X4, for STLINK-V3E only

The main clock can also be generated using an internal RC oscillator. The X2 reference clock must be disconnected by removing resistor R73 when the internal RC clock is used.

### 5.4 Reset Source

The general reset of the STM32H747I-DISCO board is active low. The reset sources are:

- Reset button B1
- STDC14 connector CN13 and TAG connector CN16 (reset from debug tools)
- ARDUINO® Uno shield board through connector CN8
- Embedded STLINK-V3E

### 5.5 Audio

A codec is connected to the SAI interface of the STM32H747XIH6. It supports the TDM feature of the SAI port. The TDM feature enables the STM32H747XIH6 to simultaneously stream two independent stereo audio channels to two separate stereo analog audio outputs. The codec communicates with the STM32H747XIH6 via the I2C4 bus, which is shared with the DSI® LCD, camera module, ARDUINO® Uno connectors, and STMod+ connector.

The audio connections are:

- The analog line input is connected to the ADC of the WM8994ECS/R through blue audio jack CN10
- The analog line output is connected to the DAC of the WM8994ECS/R via green audio jack CN11
- Two external speakers can be connected to WM8994ECS/R via JP5 for the right speaker and JP2 for the left speaker
- One MP34DT05-A digital microphone is present on the STM32H747I-DISCO board

The I<sup>2</sup>C-bus addresses of the WM8994 codec are 34h and 35h.

### 5.5.1 Digital microphone

The U21 on the STM32H747I-DISCO board is STMicroelectronics MP34DT05-A MEMS digital omnidirectional microphone providing PDM (pulse density modulation) output. The microphone is supplied with a programmable clock generated directly by the STM32H747XIH6 or the codec.

As an option, the microphone can be connected to U12 (Wolfson WM8994 audio codec device). In that configuration, WM8994 also supplies the PDM clock to the microphone.

Regardless of microphone routing (STM32H747XIH6 MCU or WM8994 codec), the power can be supplied either by VDD or the MICBIAS1 output of the WM8994 codec device.

[Table 4](#) shows the settings of all solder bridges associated to the digital microphone on the board.

**Table 4. Digital microphone-related jumper settings**

Solder bridge	Setting	Configuration
SB45, SB21, SB44, SB22	SB45, SB21 open, SB44, SB22 closed	The PDM clock for the digital microphone is provided by the codec.
	SB45, SB21 closed, SB44, SB22 open	<b>Default setting.</b> The PDM clock for the digital microphone is provided by the STM32H747XIH6 MCU.
SB42, SB41	SB41 closed, SB42 open	The power supply of the digital microphone is generated by the codec.
	SB41 open, SB42 closed	<b>Default setting.</b> The power supply of the digital microphone is +3V3.

## 5.6 USB OTG HS port

The STM32H747I-DISCO supports USB OTG HS (high-speed) communication via the U4 USB PHY with the ULPI interface. USB OTG connector CN1 is of the Micro-AB type.

### 5.6.1 STM32H747I-DISCO as USB device

The STM32H747I-DISCO board may work as USB device on CN1 in any power source configuration. If the board is supplied by an external power source from jumper JP4 set on

U5V, the user must pay attention that the power source delivers a sufficient amount of current for the complete STM32H747I-DISCO board setup.

When a USB host connection to the CN1 Micro-AB USB connector of STM32H747I-DISCO is detected, the STM32H747I-DISCO board starts behaving as a USB device. Depending on the powering capability of the USB host, the board can take power from the VBUS terminal of CN1. In the board schematics, the corresponding power voltage line is called HS.

Refer to [Section 5.2: Power supply on page 14](#) for the related jumper setting.

### 5.6.2 STM32H747I-DISCO as USB host

When a USB device connection to the CN1 Micro-AB USB connector is detected, the STM32H747I-DISCO board starts behaving as USB host. It sources 5 V on the VBUS terminal of CN1 Micro-AB USB connector to power the USB device. For this to happen, the STM32H747XIH6 MCU sets the U2 power switch to the ON state via the USB PHY. The LD7 green LED marked OTG\_HS indicates that the peripheral is supplied by the board. The LD5 red LED marked HS\_OC lights up if over-current is detected.

## 5.7 Ethernet

The STM32H747I-DISCO board supports 10 Mbps / 100 Mbps Ethernet communication with the U18 PHY and the CN7 integrated RJ45 connector. The Ethernet PHY is connected to the STM32H747XIH6 MCU via the RMII interface.

The 25 MHz clock for the PHY is generated by oscillator X2. The 50 MHz clock for the STM32H747XIH6 is provided by the RMII\_REF\_CLK of the PHY.

With the default setting, the Ethernet feature is not working because of a conflict between ETH\_MDC and SAI4\_D1 of the MEMs digital microphone. [Table 5](#) shows the possible settings of all solder bridges or resistor associated with the Ethernet on the board.

**Table 5. Ethernet related solder bridge and resistor settings**

Solder bridge / resistor	Setting	Configuration
SB8, SB21	SB8 open, SB21 closed	<b>Default setting.</b> STM32H747XIH6 port PC1 is connected to MEMs. digital microphone DOUT.
	SB8 closed, SB21 open	STM32H747XIH6 port PC1 is connected to Ethernet ETH_MDC.
SB17, R87	R87 closed, SB17 open	<b>Default setting.</b> STM32H747XIH6 port PE2 is connected to MEMs. digital microphone CLK.
	R87 open, SB17 closed	STM32H747XIH6 port PE2 is connected to Ethernet ETH_nINT.

## 5.8 SDRAM

The U7 8M x 32bit SDRAM is connected to SDRAM Bank1 of the STM32H747XIH6 FMC interface.

## 5.9 Quad-SPI flash memory

Two 512-Mbit Quad-SPI flash memory devices are fitted on STM32H747I-DISCO in positions U3 and U14, making possible the evaluation of the STM32H747XIH6 Quad-SPI interface.

## 5.10 Virtual COM port

The serial interface USART1 is directly available as a Virtual COM port of a PC connected to STLINK-V3E USB connector CN2. The Virtual COM port configuration is:

- 115200 bit/s
- 8-bit data
- no parity
- 1 stop bit

## 5.11 User LEDs

Four general-purpose color LEDs (LD1, LD2, LD3, and LD4) are available as light indicators. Each LED is in light-emitting state for a low level of the corresponding port of the STM32H747XIH6 MCU.

## 5.12 Physical input devices

The STM32H747I-DISCO board provides a number of input devices for physical human control:

- Four-way joystick controller with select key (B3)
- Wake-up / Tamper button (B2)
- Reset button (B1)

## 6 Connectors

### 6.1 USB OTG HS Micro-AB connector CN1

An USB OTG high speed communication link is available at USB Micro-AB receptacle connector CN1. Micro-AB receptacle enables USB Host and USB Device features.

Figure 8. USB OTG HS Micro-AB connector CN1

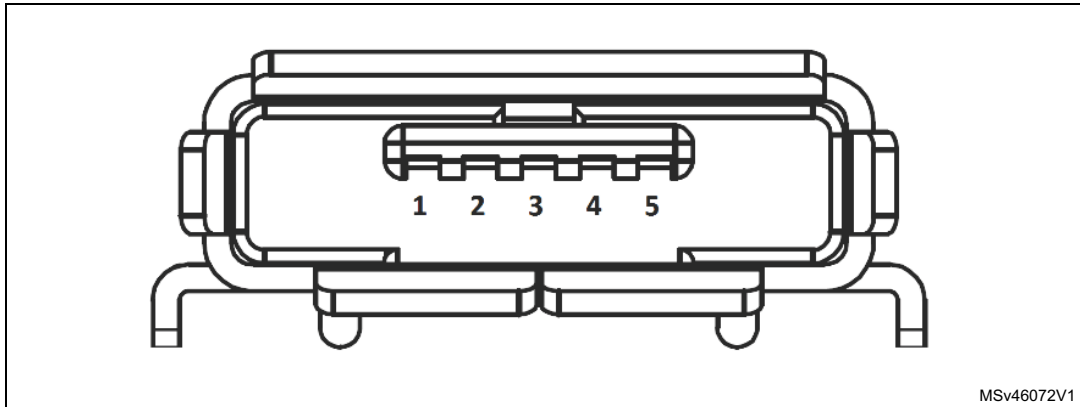


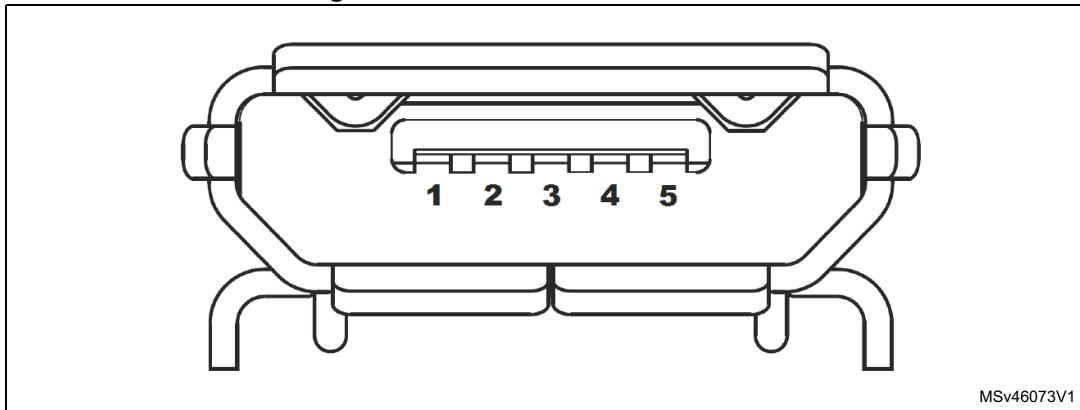
Table 6. USB OTG HS Micro-AB connector CN1

Pin number	Description	Pin number	Description
1	VBUS	4	ID
2	DM	5	GND
3	DP	-	-

## 6.2 STLINK-V3E USB Micro-B connector CN2

USB connector CN2 is used to connect the embedded STLINK-V3E to the PC for programming and debugging software.

Figure 9. USB Micro-B connector CN2



MSv46073V1

Table 7. USB Micro-B connector CN2

Pin number	Description	Pin number	Description
1	VBUS (power)	4	NC
2	DM	5	GND
3	DP	-	-

## 6.3 SPDIF input RCA connector CN3

Table 8. SPDIF input RCA connector CN3

Pin number	Description	Pin number	Description
1	SPDIF_RX0 (PD7)	3	GND
2	GND	4	GND

## 6.4 STLINK-V3E MCU programming header CN4

The 4-pin STLINK-V3E MCU programming header offers a way to program and debug an MCU in an external application board using a dedicated cable connected to it.

Table 9. STLINK-V3E MCU programming header CN4

Pin number	Description	Pin number	Description
1	3V3	3	GND
2	SWCLK (PA14)	4	SWDIO (PA13)

*Note:* The STLINK-V3E MCU programming header is not populated by default. Its use is reserved to advanced users.

## 6.5 ARDUINO<sup>®</sup> Uno V3 connectors CN5, CN6, CN8 and CN9

ARDUINO<sup>®</sup> Uno V3 connectors CN5, CN6, CN8 and CN9 are female connectors compatible with ARDUINO<sup>®</sup> Uno Revision 3 standard. Most of shields designed for ARDUINO<sup>®</sup> Uno V3 fit to STM32H747I-DISCO board.

**Table 10. ARDUINO<sup>®</sup> Uno V3 compatible connectors**

Left connectors					Right connectors				
CN number	Pin nbr.	Pin name	MCU pin	Function	Function	MCU pin	Pin name	Pin nbr.	CN number
CN8 Power	1	NC	-	-	I2C4_SCL	PD12	D15	10	CN5 Digital
	2	IOREF	-	3.3 V Ref	I2C4_SDA	PD13	D14	9	
	3	RESET	NRST	RESET	AVDD	-	AREF	8	
	4	+3V3	-	3.3 V <sup>(1)</sup> input / output	Ground	-	GND	7	
	5	+5V	-	5 V output	SPI5_SCK	PK0	D13	6	
	6	GND	-	Ground	SPI5_MISO	PJ11	D12	5	
	7	GND	-	Ground	TIM1_CH2N, SPI5_MOSI	PJ10	D11	4	
	8	VIN	-	Power input <sup>(2)</sup>	TIM1_CH1, SPI5_NSS	PK1	D10	3	
CN9 Analog	1	A0	PA4	ADC12_INP18	TIM8_CH2	PJ6	D9	2	CN6 Digital
	2	A1	PF10	ADC3_INP6	-	PJ5	D8	1	
	3	A2	PA0_C	ADC12_INP0	-	PJ0	D7	8	
	4	A3	PA1_C	ADC12_INP1	TIM8_CH2N	PJ7	D6	7	
	5	A4	PC2_C or PD13	ADC3_INP0 or I2C4_SDA <sup>(3)</sup>	TIM3_CH1	PA6	D5	6	
	6	A5	PC3_C or PD12	ADC3_INP1 or I2C4_SCL <sup>(3)</sup>	-	PJ4	D4	5	
				TIM13_CH1	PF8	D3	4		
				-	PJ3	D2	3		
				UART8_TX	PJ8	D1	2		
				UART8_RX	PJ9	D0	1		

- The +3V3 on ARD connector Pin4 of CN8 is not a power input for STM32H747I-DISCO board, to simplify power architecture.
- The external voltage applied to pin VIN on Pin8 of CN8 must be in the range 6 to 9V at 25°C ambient temperature. If a higher voltage is applied on the regulator U19, it may overheat and could be damaged.
- By default, Pin 5 and Pin 6 of CN9 connector are connected to ADC MCU input ports PC2\_C and PC3\_C respectively, thanks to configuration of solder bridges: SB6 and SB23 closed, SB7 and SB24 opened. In case it is necessary to connect I<sup>2</sup>C interface signals on pins 5 and 6 of CN9 instead of ADC inputs, open SB6 and SB23, and close SB7 and SB24.

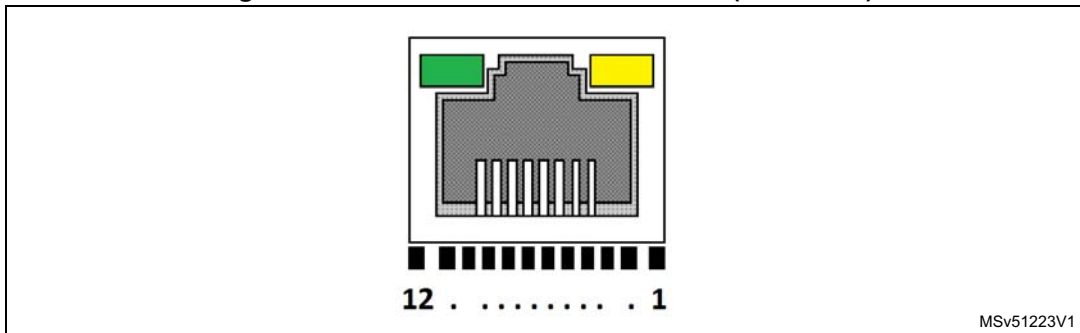


Before using any ARDUINO® Uno V3 shield, it is important to refer to [Section 5.2.1: Supplying the board through STLINK-V3E USB port on page 15](#) for a correct configuration of JP6.

**Caution:** The I/Os of the STM32 microcontroller are +3V3 compatible instead of 5 V for ARDUINO® Uno V3.

## 6.6 Ethernet RJ45 connector CN7

Figure 10. Ethernet RJ45 connector CN7 (front view)



Yellow LED: Ethernet connection.  
Green LED: Ethernet traffic.

Table 11. USB Micro-B connector CN2

Pin number	Description	Pin number	Description
1	TX+	7	CT
2	TX-	8	CT
3	RX+	9	K, yellow LED
4	CT	10	A, yellow LED
5	CT	11	K, green LED
6	RX-	12	A, green LED

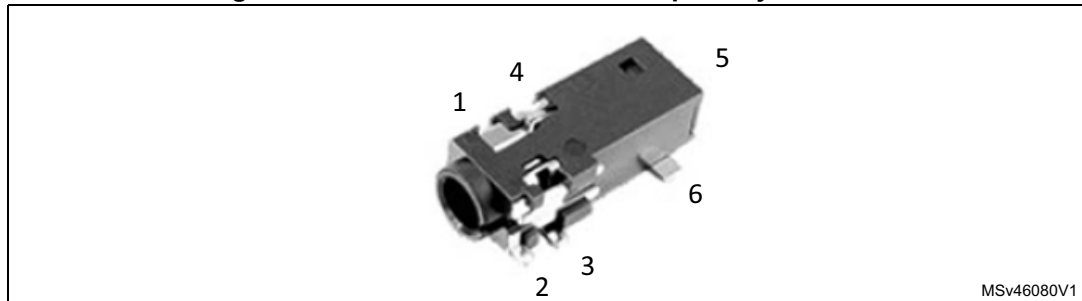
## 6.7 Audio blue jack (Line In) connector CN10

The 3.5 mm stereo audio blue jack input CN10 is available on the STM32H747I-DISCO Discovery board for audio line input.

## 6.8 Audio green jack (Line Out) connector CN11

The 3.5 mm stereo audio green jack output CN11 is available on the STM32H747I-DISCO Discovery board for headphones.

**Figure 11. Stereo headset with microphone jack CN11**



**Table 12. Audio jack connector CN11 (on board)**

Pin number	Description	Stereo headset pinning	
1	NC	NA	
2	NC	NA	
3	GND	GND	
4	OUT_Right	SPK_R (33 ohm typ.)	
5	NC	NA	
6	OUT_Left	SPK_L (33 ohm typ.)	

### 6.9 microSD™ card connector CN12

microSD™ cards with 4 Gbytes or more capacity are inserted in the receptacle CN12. Four data bits of the SDMMC1 interface, CLK and CMD signals of the STM32H747XIH6 are used to communicate with the microSD™ card at +3V3 only. The card insertion is detected by the PI8 GPIO: when a microSD™ card is inserted, the logic level is 0, otherwise it is 1.

Figure 12. microSD™ connector CN12

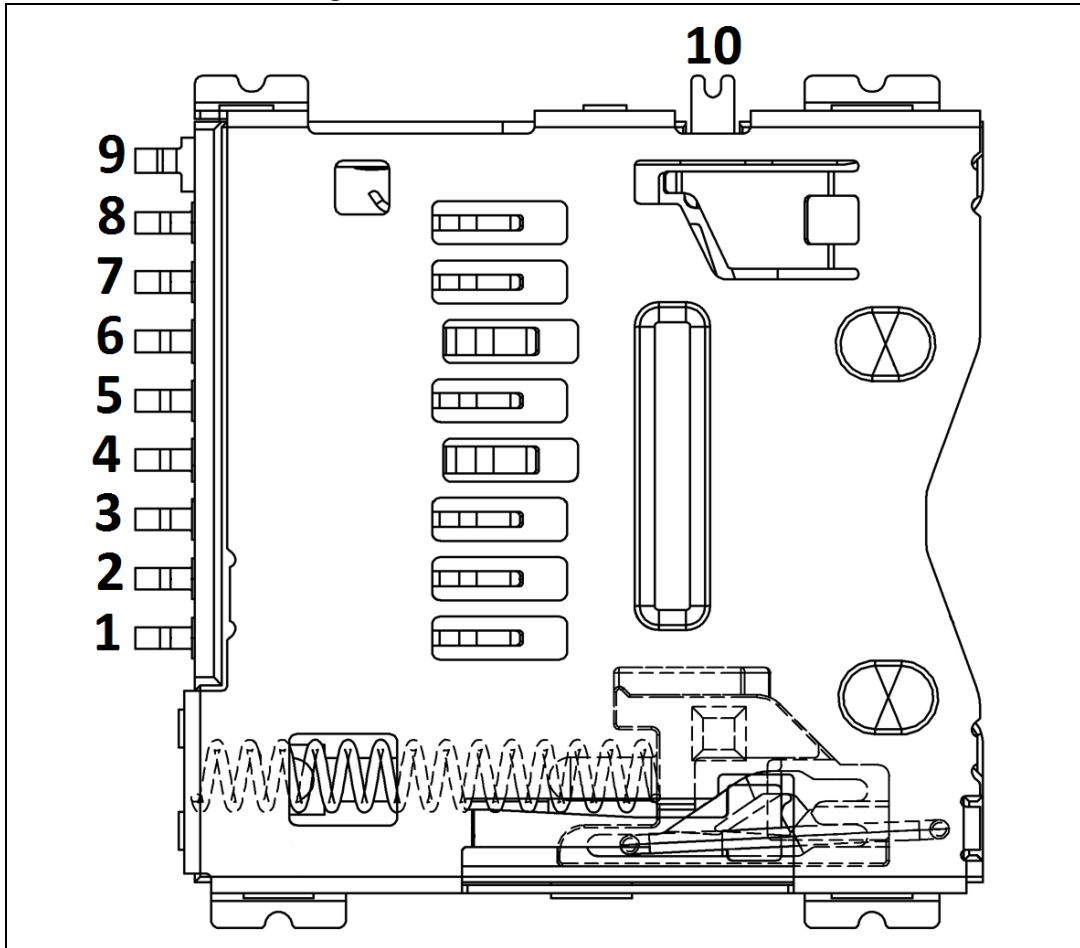


Table 13. microSD™ connector CN12

Pin number	Description	Pin number	Description
1	SDIO1_D2 (PC10)	6	GND
2	SDIO1_D3 (PC11)	7	SDIO1_D0 (PC8)
3	SDIO1_CMD (PD2)	8	SDIO1_D1 (PC9)
4	+3V3	9	GND
5	SDIO1_CK (PC12)	10	μSD_DETECT (PI8)

## 6.10 STDC14 connector CN13

Figure 13. STDC14 debugging connector CN13 (top view)

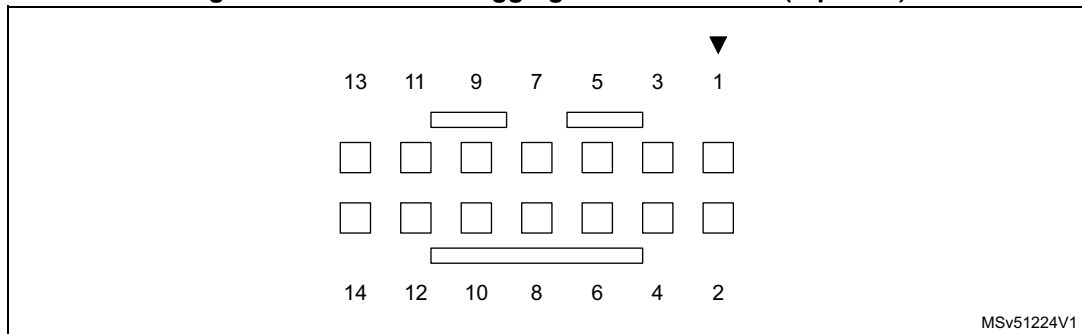


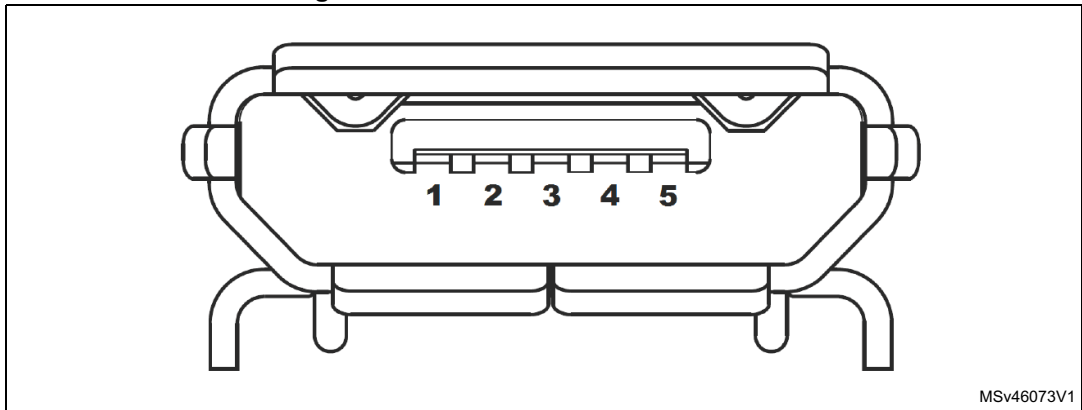
Table 14. STDC14 debugging connector CN13

Terminal	Function / MCU port	Terminal	Function / MCU port
1	-	2	-
3	VDD	4	SWDIO/TMS (PA13)
5	GND	6	SWDCLK/TCK (PA14)
7	GND	8	SWO/TDO (PB3)
9	KEY	10	TDI (PA15)
11	GND	12	RESET#
13	VCP_RX (PA10)	14	VCP_TX (PA9)

### 6.11 External 5 V USB Micro-B connector CN14

USB connector CN14 is used to provide additional external 5 V power to the STM32H747I-DISCO if more power current is consumed on the board.

Figure 14. USB Micro-B connector CN14



MSv46073V1

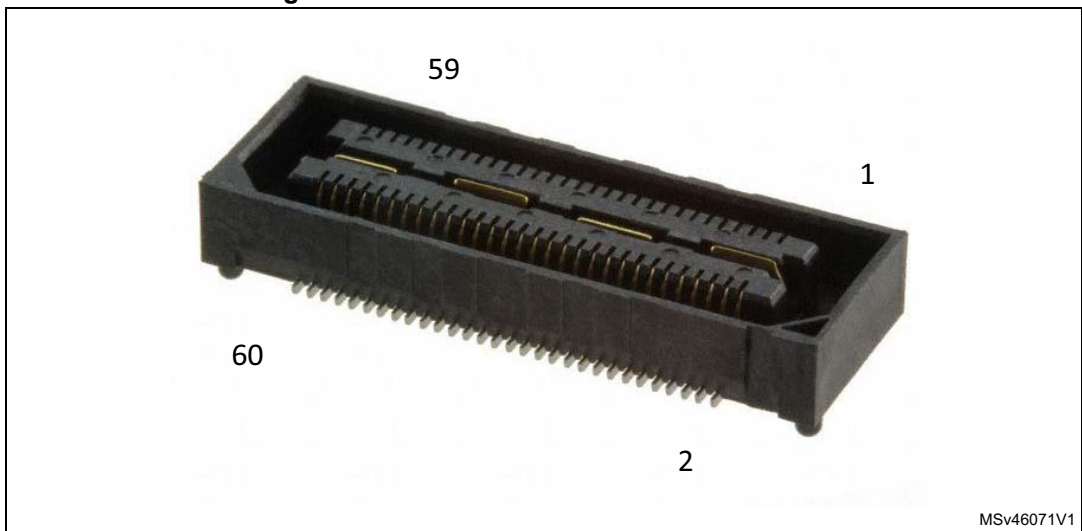
Table 15. USB Micro-B connector CN14

Pin number	Description	Pin number	Description
1	VBUS (power)	4	NC
2	NC	5	GND
3	NC	-	-

### 6.12 DSI<sup>®</sup> LCD connector CN15 (MIPI<sup>®</sup>)

The CN15 connector is designed to connect the DSI<sup>®</sup> LCD daughterboard. The MB1166 daughterboard is available to be mounted on the STM32H747I-DISCO board. [Table 16](#) shows the assignment of CN15 and STM32H747XIH6 terminals.

Figure 15. DSI<sup>®</sup> LCD module connector CN15



MSv46071V1

Table 16. DSI<sup>®</sup> LCD module connector CN15

Function	Pin connection	CN15 pin number		Pin connection	Function
GND	-	1	2	-	-
DSI_CK_P	-	3	4	PK7	DSI_INT
DSI_CK_N	-	5	6	-	GND
GND	-	7	8	GND	RFU <sup>(1)</sup>
DSI_D0_P	-	9	10	GND	RFU <sup>(1)</sup>
DSI_D0_N	-	11	12	-	GND
GND	-	13	14	GND	RFU <sup>(1)</sup>
DSI_D1_P	-	15	16	GND	RFU <sup>(1)</sup>
DSI_D1_N	-	17	18	-	GND
GND	-	19	20	-	-
BLVDD (5V)	-	21	22	-	-
BLVDD (5V)	-	23	24	-	-
-	-	25	26	-	-
BLGND	-	27	28	-	-
BLGND	-	29	30	-	-
-	-	31	32	-	-
-	-	33	34	-	-
SCLK/MCLK	PE5	35	36	-	3.3 V
LRCLK	PE4	37	38	-	-
I2S_DATA	PE6	39	40	PD13	I2C_SDA
-	-	41	42	-	-
-	-	43	44	PD12	I2C_SCL
CEC_CLK	PA8	45	46	-	-
CEC	PB6	47	48	-	-
DSI_TE	PJ2	49	50	-	-
-	-	51	52	-	-
DSI_BL_CTRL	PJ12	53	54	-	-
-	-	55	56	-	-
DSI_RST	PG3	57	58	-	-
-	-	59	60	-	1.8 V

1. Reserved for future use.

### 6.13 TAG connector CN16

The TAG connector footprint CN16 is used to connect STM32H747XIH6 microcontroller for programming or debugging the board.

Figure 16. TAG connector CN16

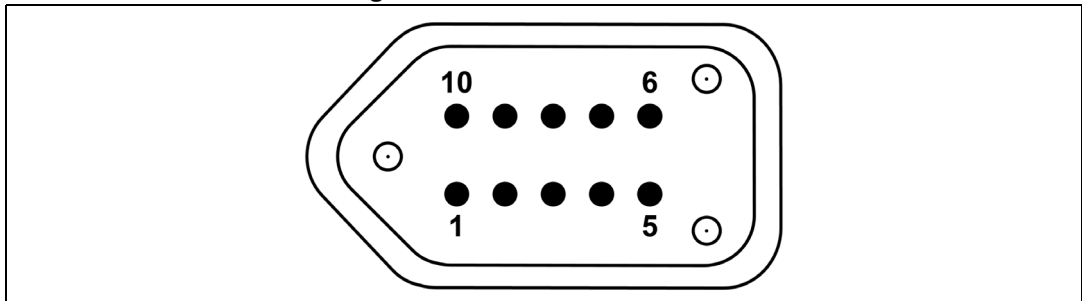


Table 17. TAG connector CN16

Pin number	Description	Pin number	Description
1	VDD	2	SWDIO/TMS (PA13)
3	GND	4	SWDCLK/TCK (PA14)
5	GND	6	SWO/TDO (PB3)
7	NC	8	TDI (PA15)
9	TRST (PB4)	10	RESET#

### 6.14 Audio connector CN17

The 2x10-male-pin 1.27 mm-pitch audio connector is used for Audio MEMS daughter board extension with the DFSDM interface.

Table 18. Audio connector CN17

Terminal	Function / MCU port	Terminal	Function / MCU port
1	GND	2	+3V3
3	DFSDM_CKOUT (PD3)	4	DFSDM_CKOUT (PD3)
5	DFSDM_DATIN3 (PC7)	6	DFSDM_DATIN7 (PB9)
7	DFSDM_DATIN1 (PC3)	8	DFSDM_DATIN2 (PB14)
9	NC	10	DETECTn (PC6)
11	NC	12	MEMS_LED (PJ13)
13	NC	14	NC
15	NC	16	NC
17	NC	18	NC
19	+3V3	20	GND

## 6.15 Camera module connector P1

An 8-bit camera module function is supported thanks to the 30-pin dedicated ZIF connector P1. The reference of the camera module to be used is STM32F4DIS-CAM. This module must be connected with caution before powering the STM32H747I-DISCO Discovery board. The camera module I<sup>2</sup>C addresses are 0x61 and 0x60. The camera is usable by default. Care must be taken of GPIO sharing and multiplexing with other functions, in order to program the good configuration.

GPIO assignment and sharing:

- DCMI\_SDA and DCMI\_SCL I<sup>2</sup>C peripheral shared with Pmod™/STMOD+ connector, ARDUINO® connector, and audio DSI® LCD
- Camera signals PA4, PC6, PC7, PB8, PB9, PD3 shared with Pmod™
- Camera signals PC9 and PC11 shared with SDIO
- Camera signal PA6 shared with ARDUINO®

Figure 17. Camera module connector P1 (front view)

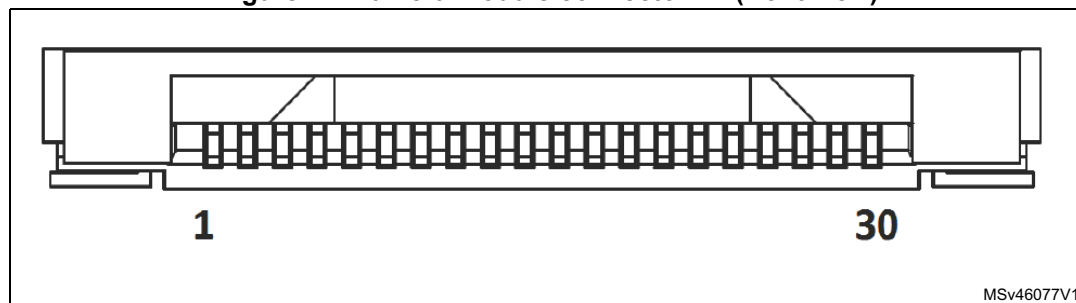


Table 19. Camera module connector P1

Pin number	Description	Pin number	Description
1	GND	16	GND
2	NC	17	DCMI_HSYNC (PA4)
3	NC	18	NC
4	DCMI_D0 (PC6)	19	DCMI_VSYNC (PB7)
5	DCMI_D1 (PC7)	20	3V3
6	DCMI_D2 (PG10)	21	Camera_CLK (OSC_24M)
7	DCMI_D3 (PC9)	22	NC
8	DCMI_D4 (PC11)	23	GND
9	DCMI_D5 (PD3)	24	NC
10	DCMI_D6 (PB8)	25	DCMI_PWR_EN (PJ14)
11	DCMI_D7 (PB9)	26	RESET#
12	NC	27	DCMI_SDA (PD13)
13	NC	28	DCMI_SCL (PD12)
14	GND	29	GND
15	DCMI_PIXCK (PA6)	30	3V3



## 6.16 STMod+ connector P2

The standard 20-pin STMod+ connector is available on the STM32H747I-DISCO board to increase the compatibility with external boards and modules from the microcontrollers ecosystem. By default, it is designed to support an ST dedicated fan-out board, which allows connecting different modules or board extensions from different manufacturers. The fan-out board also embeds a 3V3 regulator. For more detailed information, refer to the STMicroelectronics fan-out board user manual, and to the relevant datasheets of the associated modules.

For details about STMod+ interface, refer to the STMod+ connector interface specification.

Figure 18. STMod+ connector P2

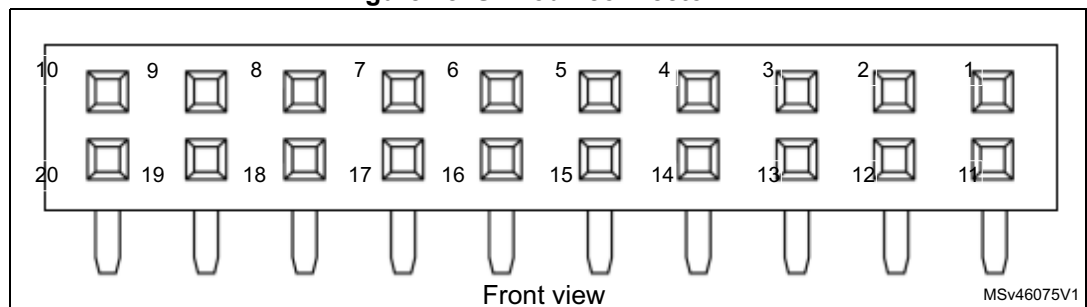


Table 20. STMod+ connector P2

Pin number	Description	Pin number	Description
1	SPI2_NSS/USART2_CTS (PA11/PA0)	11	INT (PC6)
2	SPI2_MOSI/ USART2_TX (PC3/PD5)	12	RESET (PJ13)
3	SPI2_MISO/ USART2_RX (PC2/PD6)	13	ADC (PA4)
4	SPI2_SCK/ USART2_RTS (PA12/PD4)	14	PWM (PF8)
5	GND	15	+5 V
6	+5 V	16	GND
7	I2C4_SCL (PD12)	17	DFSDM-DATA3 (PC7)
8	SPI2_MOSIs (PB15)	18	DFSDM-CKOUT (PD3)
9	SPI2_MISOs (PB14)	19	DFSDM-DATA7 (PB9)
10	I2C4_SDA (PD13)	20	DFSDM-CK7 (PB8)

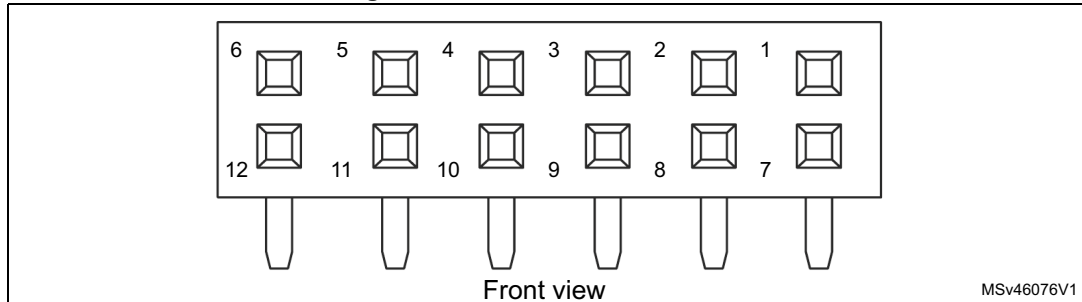
This connector shares many GPIOs with other functions on the board. For more detailed information, refer to [Appendix A: STMod+ GPIO sharing and multiplexing](#).

In addition, to have a quick look at STMod+ GPIO sharing and multiplexing, and to get a quick view on other Alternate functions available on its pins, refer to [Appendix A: STMod+ GPIO sharing and multiplexing](#).

## 6.17 Pmod™ connector P3

The standard 12-pin Pmod™ connector is available on the STM32H747I-DISCO Discovery board to support low frequency, low I/O pin count peripheral modules. The Pmod™ interface implemented on the STM32H747I-DISCO Discovery board is compatible with the Pmod™ type 2A & 4A I/O signal assignment convention.

**Figure 19. Pmod™ connector P3**



**Table 21. Pmod™ connector P3**

Pin number	Description	Pin number	Description
1	SPI2_NSS/USART2_CTS (PA11/PA0)	7	INT (PC6)
2	SPI2_MOSI/ USART2_TX (PC3/PD5)	8	RESET (PJ3)
3	SPI2_MISO/ USART2_RX (PC2/PD6)	9	NA
4	SPI2_SCK/ USART2_RTS (PA12/PD4)	10	NA
5	GND	11	GND
6	+3V3	12	+3V3

Pmod™ also shares GPIOs with other functions of the board. For more detailed information, refer to [Appendix A: STMod+ GPIO sharing and multiplexing](#).

## 7 STM32H747I-DISCO I/O assignment

Table 22. STM32H747I-DISCO I/O assignment

Pin	GPIO port	GPIO primary interface
A1	VSS	-
A10	PG9	QSPI_BK2_IO2
A11	PD5	PMOD#2- USART2_TX
A12	PD4	PMOD#4- USART2_RTS
A13	PC10	SDIO1_D2
A14	PA15	JTDI
A15	PI1	FMC_D25
A16	PI0	FMC_D24
A17	VSS	-
A2	PI6	FMC_D28
A3	PI5	FMC_NBL3
A4	PI4	FMC_NBL2
A5	PB5	ULPI_D7
A6	VDDLDO	-
A7	VCAP	-
A8	PK5	JOY_RIGHT
A9	PG10	DCMI_D2
B1	VBAT	-
B10	PJ15	Audio_INT
B11	PD6	PMOD#3- USART2_RX
B12	PD3	PMOD#18_DFSDM_CKOUT/DCMI_D5
B13	PC11	SDIO1_D3    DCMI_D4
B14	PA14	JTCK-SWCLK
B15	PI2	FMC_D26
B16	PH15	FMC_D23
B17	PH14	FMC_D22
B2	VSS	-
B3	PI7	FMC_D29
B4	PE1	FMC_NBL1
B5	PB6	HDMI_CEC
B6	VSS	-
B7	PB4	NJTRST

Table 22. STM32H747I-DISCO I/O assignment (continued)

Pin	GPIO port	GPIO primary interface
B8	PK4	JOY_LEFT
B9	PG11	ETH_TX_EN/TX_EN
C1	PC15-OSC32_OUT	OSC32_OUT
C10	VSS	-
C11	PD7	SPDIF_RX0
C12	PC12	SDIO1_CK
C13	VSS	-
C14	PI3	FMC_D27
C15	PA13	JTMS-SWDIO
C16	VSS	-
C17	VDDLDO	-
C2	PC14-OSC32_IN	OSC32_IN
C3	PE2	ETH_nINT    SAI4_CK1
C4	PE0	FMC_NBL0
C5	PB7	DCMI_VSYNC
C6	PB3	JTDO/TRACESWO
C7	PK6	JOY_UP
C8	PK3	JOY_DOWN
C9	PG12	ETH_TXD1/TXD1
D1	PE5	SAI1_SCK_A
D10	PJ14	DCMI_PWR_EN
D11	PJ12	BL_CTRL
D12	PD2	SDIO1_CMD
D13	PD0	FMC_D2
D14	PA10	VCP-USART1_RX
D15	PA9	VCP-USART1_TX
D16	PH13	FMC_D21
D17	VCAP	-
D2	PE4	SAI1_FS_A
D3	PE3	SAI1_SD_B
D4	PB9	PMOD#19_DFSDM-DATA7    DCMI_D7
D5	PB8	PMOD#20_DFSDM-CK7    DCMI_D6
D6	PG15	FMC_SDNCAS
D7	PK7	TOUCH_INT
D8	PG14	QSPI_BK2_IO3

Table 22. STM32H747I-DISCO I/O assignment (continued)

Pin	GPIO port	GPIO primary interface
D9	PG13	ETH_/TXD0/TXD0
E1	VLXSMPS	-
E10	PJ13	PMOD#12_GPIO
E11	VDD	-
E12	PD1	FMC_D3
E13	PC8	SDIO1_D0
E14	PC9	SDIO1_D1    DCMI_D3
E15	PA8	CEC_CK    MCO1
E16	PA12	PMOD#4-SPI2_SCK/2_CK
E17	PA11	PMOD#1-SPI2_NSS/2_WS
E2	PI9	FMC_D30
E3	PC13	TAMP_1/WKUP2
E4	PI8	uSD_Detect
E5	PE6	SAI1_SD_A
E6	VDD	-
E7	PDR_ON	-
E8	BOOT0	-
E9	VDD	-
F1	VDDSMPS	-
F13	PC7	PMOD#17_DFSDM_DATA3/DCMI_D1
F14	PC6	PMOD#11_INT/DCMI_D0
F15	PG8	FMC_SDCLK
F16	PG7	SAI1_MCLK_A
F17	VDD33USB	-
F2	VSSSMPS	-
F3	PI10	FMC_D31
F4	PI11	ULPI_DIR
F5	VDD	-
G1	PF2	FMC_A2
G10	VSS	-
G11	VSS	-
G13	VDD	-
G14	PG5	FMC_BA1
G15	PG6	QSPI_BK1_NCS
G16	VSS	-

Table 22. STM32H747I-DISCO I/O assignment (continued)

Pin	GPIO port	GPIO primary interface
G17	VDD50USB	-
G2	VFBSMPS	-
G3	PF1	FMC_A1
G4	PF0	FMC_A0
G5	VDD	-
G7	VSS	-
G8	VSS	-
G9	VSS	-
H1	PI12	LED1
H10	VSS	-
H11	VSS	-
H13	VDD	-
H14	PG4	FMC_BA0
H15	PG3	DSI_Reset
H16	PG2	FMC_A12
H17	PK2	JOY_SEL
H2	PI13	LED2
H3	PI14	LED3
H4	PF3	FMC_A3
H5	VDD	-
H7	VSS	-
H8	VSS	-
H9	VSS	-
J1	PH1 - OSC_OUT	OSC_OUT
J10	VSS	-
J11	VSS	-
J13	VDD	-
J14	PK0	ARD_D13-SPI5_SCK
J15	PK1	ARD_D10-SPI5_NSS    TIM1_CH1
J16	VSS	-
J17	VSS	-
J2	PH0 - OSC_IN	OSC_IN
J3	VSS	-
J4	PF5	FMC_A5
J5	PF4	FMC_A4

Table 22. STM32H747I-DISCO I/O assignment (continued)

Pin	GPIO port	GPIO primary interface
J7	VSS	-
J8	VSS	-
J9	VSS	-
K1	NRST	NRST
K10	VSS	-
K11	VSS	-
K13	VDD	-
K14	PJ11	ARD_D12-SPI5_MISO
K15	VSSDSI	-
K16	DSI_D1P	-
K17	DSI_D1N	-
K2	PF6	QSPI_BK1_IO3
K3	PF7	QSPI_BK1_IO2
K4	PF8	PMOD#14_PWM    ARD_D3-TIM13_CH1
K5	VDD	-
K7	VSS	-
K8	VSS	-
K9	VSS	-
L1	VDDA	-
L10	VSS	-
L11	VSS	-
L13	VDD	-
L14	PJ10	ARD_D11-SPI5_MOSI    TIM1_CH2N
L15	VSSDSI	-
L16	DSI_CKP	-
L17	DSI_CKN	-
L2	PC0	ULPI_STP
L3	PF10	ARD_A1
L4	PF9	QSPI_BK1_IO1
L5	VDD	-
L7	VSS	-
L8	VSS	-
L9	VSS	-
M1	VREF+	-
M13	VDD	-

Table 22. STM32H747I-DISCO I/O assignment (continued)

Pin	GPIO port	GPIO primary interface
M14	PJ9	ARD_D0-UART8_RX
M15	VSSDSI	-
M16	DSI_D0P	-
M17	DSI_D0N	-
M2	PC1	ETH_MDC    SAI4_D1
M3	PC2	PMOD#3-SPI2_MISO/2_SDI
M4	PC3	PMOD#2-SPI2_MOSI/2_SDO
M5	VDD	-
N1	VREF-	-
N10	VDD	-
N11	VDD	-
N12	VDD	-
N13	PJ8	ARD_D1-UART8_TX
N14	PJ7	ARD_D6-TIM8_CH2N
N15	PJ6	ARD_D9-TIM8_CH2
N16	VSS	-
N17	VCAPDSI	-
N2	PH2	QSPI_BK2_IO0
N3	PA2	ETH_MDIO
N4	PA1	ETH_/RX_CLK/REF_CLK/CLK
N5	PA0	PMOD#1- USART2_CTS_NSS
N6	PJ0	ARD_D7
N7	VDD	-
N8	VDD	-
N9	PE10	FMC_D7
P1	VSSA	-
P10	PE11	FMC_D8
P11	PB10	ULPI_D3
P12	PB11	ULPI_D4
P13	PH10	FMC_D18
P14	PH11	FMC_D19
P15	PD15	FMC_D1
P16	PD14	FMC_D0
P17	VDDDSI	-
P2	PH3	QSPI_BK2_IO1



Table 22. STM32H747I-DISCO I/O assignment (continued)

Pin	GPIO port	GPIO primary interface
P3	PH4	ULPI_NXT
P4	PH5	FMC_SDNWE
P5	PI15	LED4
P6	PJ1	OTG_HS_OverCurrent
P7	PF13	FMC_A7
P8	PF14	FMC_A8
P9	PE9	FMC_D6
R1	PC2_C	ARD_A4
R10	PE12	FMC_D9
R11	PE15	FMC_D12
R12	PJ5	ARD_D8
R13	PH9	FMC_D17
R14	PH12	FMC_D20
R15	PD11	QSPI_BK1_IO0
R16	PD12	PMOD#7/ARD_D15-I2C4_SCL
R17	PD13	PMOD#10/ARD_D14-I2C4_SDA
R2	PC3_C	ARD_A5
R3	PA6	ARD_D5-TIM3_CH1    DCMI_PIXCLK
R4	VSS	-
R5	PA7	ETH_RX_DV/CRS_DV/SYNC
R6	PB2	QSPI_CLK
R7	PF12	FMC_A6
R8	VSS	-
R9	PF15	FMC_A9
T1	PA0_C	ARD_A2
T10	PE13	FMC_D10
T11	PH6	FMC_SDNE1
T12	VSS	-
T13	PH8	FMC_D16
T14	PB12	ULPI_D5
T15	PB15	PMOD#8-SPI2_MOSI/2_SDO
T16	PD10	FMC_D15
T17	PD9	FMC_D14
T2	PA1_C	ARD_A3
T3	PA5	ULPI_CK

Table 22. STM32H747I-DISCO I/O assignment (continued)

Pin	GPIO port	GPIO primary interface
T4	PC4	ETH_/RXD0/RXD0/RXD
T5	PB1	ULPI_D2
T6	PJ2	DSI_TE
T7	PF11	FMC_SDNRAS
T8	PG0	FMC_A10
T9	PE8	FMC_D5
U1	VSS	-
U10	PE14	FMC_D11
U11	VCAP1	-
U12	VDDLDO	-
U13	PH7	FMC_SDCKE1
U14	PB13	ULPI_D6
U15	PB14	PMOD#9-SPI2_MISO/2_SDI
U16	PD8	FMC_D13
U17	VSS	-
U2	PA3	ULPI_D0
U3	PA4	PMOD#13_ADC    ARD_A0    DCMI_HSYNC
U4	PC5	ETH_/RXD1/RXD1
U5	PB0	ULPI_D1
U6	PJ3	ARD_D2
U7	PJ4	ARD_D4
U8	PG1	FMC_A11
U9	PE7	FMC_D4

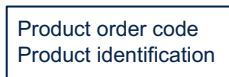
## 8 STM32H747I-DISCO Discovery kit information

### 8.1 Product marking

The stickers located on the top or bottom side of all PCBs provide product information:

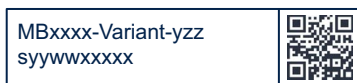
- First sticker: product order code and product identification, generally placed on the main board featuring the target device.

Example:



- Second sticker: board reference with revision and serial number, available on each PCB.

Example:



On the first sticker, the first line provides the product order code, and the second line the product identification.

On the second sticker, the first line has the following format: "MBxxxx-Variant-yyz", where "MBxxxx" is the board reference, "Variant" (optional) identifies the mounting variant when several exist, "y" is the PCB revision and "zz" is the assembly revision, for example B01. The second line shows the board serial number used for traceability.

Parts marked as "ES" or "E" are not yet qualified and therefore not approved for use in production. ST is not responsible for any consequences resulting from such use. In no event will ST be liable for the customer using any of these engineering samples in production. ST's Quality department must be contacted prior to any decision to use these engineering samples to run a qualification activity.

"E" or "ES" marking examples of location:

- On the targeted STM32 that is soldered on the board (for an illustration of STM32 marking, refer to the STM32 datasheet *Package information* paragraph at the [www.st.com](http://www.st.com) website).
- Next to the evaluation tool ordering part number that is stuck or silk-screen printed on the board.

Some boards feature a specific STM32 device version, which allows the operation of any bundled commercial stack/library available. This STM32 device shows a "U" marking option at the end of the standard part number and is not available for sales.

To use the same commercial stack in their applications, the developers might need to purchase a part number specific to this stack/library. The price of those part numbers includes the stack/library royalties.

## 8.2 STM32H747I-DISCO product history

Table 23. Product history

Order code	Product identification	Product details	Product change description	Product limitations
STM32H747I-DISC1	32H747IDISC1/	MCU: – 32H747XIH6M\$7 revision "V"	Initial revision	No limitation
		MCU errata sheet: – STM32H745/747xl/G and STM32H755/757xl device limitations (ES0445)		
STM32H747I-DISC1	DK32H747I1\$AT1	Boards: – MB1248-H747I-D02 (main board) – MB1280-DEFAULT-B01 (STMod+ fan-out board)	SB30 closed by default on MB1248.	No limitation
		MCU: – 32H747XIH6M\$7 revision "V"		
STM32H747I-DISCO	32H747IDISCO/	MCU: – 32H747XIH6M\$7 revision "V"	Initial revision	No limitation
		MCU errata sheet: – STM32H745/747xl/G and STM32H755/757xl device limitations (ES0445)		
STM32H747I-DISCO	32H747IDISCO/	Boards: – MB1166-DEFAULT-A03 (LCD daughterboard) – MB1248-H747I-D02 (main board) – MB1280-DEFAULT-B01 (STMod+ fan-out board)	Initial revision	No limitation
		MCU: – 32H747XIH6M\$7 revision "V"		

Table 23. Product history (continued)

Order code	Product identification	Product details	Product change description	Product limitations
STM32H747I-DISCO	DK32H747I\$AT1	MCU: – 32H747XIH6M\$7 revision "V"	SB30 closed by default on MB1248.	No limitation
		MCU errata sheet: – STM32H745/747xl/G and STM32H755/757xl device limitations (ES0445)		
		Boards: – MB1166-DEFAULT-A03 (LCD daughterboard) – MB1248-H747I-D03 (main board) – MB1280-DEFAULT-B01 (STMod+ fan-out board)		
STM32H747I-DISCO	DK32H747I\$AT2	MCU: – 32H747XIH6M\$7 revision "V"	<ul style="list-style-type: none"> <li>– Variant 3V3 of MB1280 with update of some EOL components</li> <li>– The product uses MB1166-DEFAULT-A09 including another display reference</li> <li>– Packaging: plastic blister replaced by a carton box</li> </ul>	No demonstration software is provided for this product identification.
		MCU errata sheet: – STM32H745/747xl/G and STM32H755/757xl device limitations (ES0445)		
		Boards: – MB1166-DEFAULT-A09 (LCD daughterboard) – MB1248-H747I-D03 (main board) – MB1280-3V3-C01 (STMod+ fan-out board)		
STM32H747I-DISCO	DK32H747I\$AT3	MCU: – 32H747XIH6M\$7 revision "V"	The product uses MB1166-DEFAULT-A10 including another display reference.	No demonstration software is provided for this product identification.
		MCU errata sheet: – STM32H745/747xl/G and STM32H755/757xl device limitations (ES0445)		
		Boards: – MB1166-DEFAULT-A10 (LCD daughterboard) – MB1248-H747I-D03 (main board) – MB1280-3V3-C01 (STMod+ fan-out board)		

## 8.3 Board revision history

**Table 24. Board revision history**

Board reference	Board variant and revision	Board change description	Board limitations
MB1166 (LCD daughterboard)	DEFAULT-A03	Initial revision	No limitation
	DEFAULT-A09	LCD FRIDA FRD397B25009-D-CTK is replaced by FRIDA FRD400B25025-A-CTK.	No limitation
	DEFAULT-A10	LCD FRIDA FRD400B25025-A-CTK is replaced by FRIDA FRD400B25021-B-CTQ.	No limitation
MB1248 (main board)	H474I-D02	Initial revision	No limitation
	H474I-D03	SB30 closed by default.	No limitation
MB1280 (STMod+ fan-out board)	DEFAULT-B01	Initial revision	No limitation
	3V3-C01	<ul style="list-style-type: none"> <li>– Several part references updated due to obsolescence (such as inductor or others; refer to the bill of material for details)</li> <li>– T1 and T2 different wiring</li> <li>– Silkscreens, logos, and PCB mechanical size updated</li> </ul>	No limitation

## 9 Federal Communications Commission (FCC) and ISED Canada Compliance Statements

### 9.1 FCC Compliance Statement

#### 9.1.1 Part 15.19

This device complies with Part 15 of the FCC Rules. Operation is subject to the following two conditions: (1) this device may not cause harmful interference, and (2) this device must accept any interference received, including interference that may cause undesired operation.

#### 9.1.2 Part 15.21

Any changes or modifications to this equipment not expressly approved by STMicroelectronics may cause harmful interference and void the user's authority to operate this equipment.

#### 9.1.3 Part 15.105

This equipment has been tested and found to comply with the limits for a Class A digital device, pursuant to part 15 of the FCC Rules. These limits are designed to provide reasonable protection against harmful interference when the equipment is operated in a commercial environment. This equipment generates, uses, and can radiate radio frequency energy and, if not installed and used in accordance with the instruction manual, may cause harmful interference to radio communications. Operation of this equipment in a residential area is likely to cause harmful interference in which case the user will be required to correct the interference at his own expense.

Note: Use only shielded cables.

#### **Responsible party (in the USA)**

Terry Blanchard

Americas Region Legal | Group Vice President and Regional Legal Counsel, The Americas STMicroelectronics, Inc.

750 Canyon Drive | Suite 300 | Coppell, Texas 75019

USA

Telephone: +1 972-466-7845

### 9.2 ISED Compliance Statement

#### **Compliance Statement**

ISED Canada ICES-003 Compliance Label: CAN ICES-3 (A) / NMB-3 (A).

#### **Déclaration de conformité**

Étiquette de conformité à la NMB-003 d'ISDE Canada : CAN ICES-3 (A) / NMB-3 (A).

## 10 CE conformity

### 10.1 Warning

#### **EN 55032 / CISPR32 (2012) Class A product**

Warning: This device is compliant with Class A of EN55032 / CISPR32. In a residential environment, this equipment may cause radio interference.

Avertissement : cet équipement est conforme à la Classe A de la EN55032 / CISPR 32. Dans un environnement résidentiel, cet équipement peut créer des interférences radio.





# Appendix A STMod+ GPIO sharing and multiplexing

Table 25. STMod+ GPIO sharing and multiplexing

Shared or exclusive functions				STMod+(1)							Shared or exclusive functions					
DFSDM	ARD	Pmod™	Some other Alternate Functions(2)	Basic	SB	Port	Pins	Port	SB	Basic	Some other Alternate Functions(2)	Pmod™	ARD	DFSDM	DCMI	
-	-	CTSS2 CSN2	ADC123_IN0, TIM5_CH1 CNA1_RX, USART1_CTS	CTSS2 NSS2	31 32	PA0 PA11	1	11	PC6	-	INT	TIM3_CH1, TIM8_CH1, USART6_TX	INT	-	CK3	D0
DATA1	-	TXS3 MOSI2	CAN1_TXFD, USART2_RX ADC123_IN13	TXS2 MOSI2	33 34	PD5 PC3	2	12	PJ13	-	RST	-	RST	-	-	-
DATA1 CKOUT	-	RXS3 MISO2	USART2_TX ADC123_IN12	RXS2 MISO2	35 36	PD6 PC2	3	13	PA4	-	ADC	ADC12_IN4, TIM5_ETR, DAC1_OUT	-	A0	-	HSYNC
-	-	RTSS3 SCK2	CAN1_RXFD TIM1_ETR, CAN1_TX, USART1_RTS	RTSS2 SCK2	37 38	PD4 PA12	4	14	PF8	-	PWM	ADC3_IN6, TIM13_CH1	-	D3	-	-
-	-	-	-	GND	-	GND	5	15	+5V	-	+5V	-	-	-	-	-
-	-	-	-	+5V	-	+5V	6	16	GND	-	GND	-	-	-	-	-
-	SCL4	-	TIM4_CH1	SCL4	-	PD12	7	17	PC7	-	GPIO	TIM3_CH2, TIM8_CH2, USART6_RX	-	-	-	D1
CK2	-	-	TIM1_CH3N, TIM8_CH3N, TIM12_CH2, USART1_RX	MOSI2	-	PB15	8	18	PD3*	-	GPIO	-	-	-	CKOUT	D5
DATA2	-	-	TIM1_CH2N, TIM8_CH2N, TIM12_CH1, USART1_TX	MISO2	-	PB14	9	19	PB9	-	GPIO	TIM4_CH4, TIM17_CH1, CAN1_TX, I2C1_SDA	-	-	DATA7	D7
-	SDA4	-	TIM4_CH2	SDA4	-	PD13	10	20	PB8*	-	GPIO	TIM4_CH3, TIM16_CH1, CAN1_RX, I2C1_SCL	-	-	CK7	D6

Legend:  
 = DFSDM   
 = ARDUINO® Uno   
 = Pmod™   
 = Alternate Functions   
 = STMod+   
 = CAM   
 = DCMI   
 = Supply   
 = GND

1. **Table 25** gives the description of the signals available on the STMod+ connector. It also shows which signal is shared with other board connector or function. The I<sup>2</sup>C bus on pins 19 / 20 might be shared with built-in Discovery slave devices. Check the slave address of any new device when adding it to the bus.
2. RTSS2 stands for USART2\_RTS, CTSS2 stands for USART2\_CTS, RXS2 stands for USART2\_RX, TXS2 stands for USART2\_TX, MOSI2 stands for SPI2\_MOSI, MISO2 stands for SPI2\_MISO, NSS2 stands for SPI2\_NSS, SCK2 stands for SPI2\_SCK, SDA4 stands for I2C4\_SDA, SCL4 stands for I2C4\_SCL, RST stands for RESET, INT stands for INTERRUPT.

## Revision history

**Table 26. Document revision history**

Date	Revision	Changes
23-Nov-2018	1	Initial version
29-Mar-2019	2	Updated schematics from <a href="#">Figure 20</a> to <a href="#">Figure 34</a> in <a href="#">Chapter 7: Schematic diagrams</a> . Updated board views in <a href="#">Figure 1</a> , <a href="#">Figure 2</a> , and <a href="#">Figure 3</a> in the cover page. Reorganized <a href="#">Chapter 2: Ordering information</a> and <a href="#">Chapter 3: Development environment</a> . Updated <a href="#">Table 1: Ordering information</a> . Added <a href="#">Section 2.1: Product marking</a> and <a href="#">Section 2.2: Codification</a> .
10-Sep-2019	3	Updated Quad-SPI Flash memory device reference in <a href="#">Section 5.9: Quad-SPI Flash memory</a> .
3-Jan-2020	4	Updated <a href="#">Section 5.7: Ethernet</a> for Ethernet setting; Added <a href="#">Table 5: Ethernet related solder bridge and resistor settings</a> . Updated <a href="#">Section 5.2.3: SMPS/LDO power supply</a> with hardware/firmware mismatch deadlock recovery.
4-May-2023	5	Added <a href="#">Chapter 8: STM32H747I-DISCO Discovery kit information</a> including <a href="#">Section 8.2: STM32H747I-DISCO product history</a> . Added <a href="#">Chapter 9: Federal Communications Commission (FCC) and ISED Canada Compliance Statements</a> and <a href="#">Chapter 10: CE conformity</a> . Updated <a href="#">Chapter 2: Ordering information</a> and <a href="#">Chapter 3: Development environment</a> . Updated <a href="#">Figure 4: STM32H747I-DISCO hardware block diagram</a> , <a href="#">Figure 5: STM32H747I-DISCO board layout (top view)</a> , and <a href="#">Figure 6: STM32H747I-DISCO board layout (bottom view)</a> . Removed <a href="#">Section 3.3: Demonstration software</a> and <a href="#">Chapter 7: Schematic diagrams</a> .
13-Sep-2023	6	Updated the description of CN5 (pin 6) and CN9 (pins 1 to 6) in <a href="#">Table 10: ARDUINO® Uno V3 compatible connectors</a> .

**IMPORTANT NOTICE – READ CAREFULLY**

STMicroelectronics NV and its subsidiaries (“ST”) reserve the right to make changes, corrections, enhancements, modifications, and improvements to ST products and/or to this document at any time without notice. Purchasers should obtain the latest relevant information on ST products before placing orders. ST products are sold pursuant to ST’s terms and conditions of sale in place at the time of order acknowledgment.

Purchasers are solely responsible for the choice, selection, and use of ST products and ST assumes no liability for application assistance or the design of purchasers’ products.

No license, express or implied, to any intellectual property right is granted by ST herein.

Resale of ST products with provisions different from the information set forth herein shall void any warranty granted by ST for such product.

ST and the ST logo are trademarks of ST. For additional information about ST trademarks, refer to [www.st.com/trademarks](http://www.st.com/trademarks). All other product or service names are the property of their respective owners.

Information in this document supersedes and replaces information previously supplied in any prior versions of this document.

© 2023 STMicroelectronics – All rights reserved