

TFT-LCD SPECIFICATION

Module No: ER-TFT103-1

Preliminary Specification

Final Specification

Customer	
Prepared by	
Approved by	

Century	
Prepared by	
Approved by	

Preliminary Product Specification

保管單位 Storage	PM
保存年限 Retention Period	3年

Contents	Page
A. General Specification	3
B. Absolute Maximum Ratings	4
C. Pin Assignment	4
D. Optical Specifications	7
E. Electronic Specification	10
F. Safety	15
G. Display quality	15
H. Handling precaution	15
I. Reliability Test Item	16
J. Packing Form	17
K. Code rule	18

Preliminary Product Specification

保管單位 Storage	PM
保存年限 Retention Period	3年

A. General Specifications

(1) Overview

The ER-TFT103-1 is a 10.25-inch LCD Cell with thin film transistors as active elements and contains 1920x720pixels. Each pixel is divided into red, green and blue dot, which are arrange in vertical stripe. The FOG is normally black mode, and can be applied to the transmission type display. Backlight unit (BLU) is not built in.

(2) General Specification

NO.	Item	Specification
1	Display resolution (pixel)	1920*RGB*720
2	Active area (mm)	243.648mm x 91.368mm
3	Screen size (inch)	10.25
4	Pixel pitc (mm)	0.1269mm x 0.1269mm
5	Outline Dimension (mm)	265.2mm x 109.2mm x 9.35mm
6	Weight (g)	110g
7	Surface treatment	HC/HC
8	Interface	LVDS
9	Shipment	FOG
10	Contrast ratio	1100
11	Response Time	20ms
12	Transmittance	2.4%

Preliminary Product Specification

保管單位 Storage	PM
保存年限 Retention Period	3年

B. Absolute Maximum Ratings

LCM					
Item	Symbol	Min	MAX	Unit	Remark
Power Supply Voltage 1	VCC1	0.3	3.6	V	
Power Supply Voltage 2	VSP	0.3	6.5	V	
Power Supply Voltage 3	VSN	-6.5	-0.3	V	
Power Supply Voltage 5	VGH	-0.3	25	V	Note1
Power Supply Voltage 6	VGL	-20	-0.3	V	Note1

Note1 : VGH、VGL在极值电压条件下，只能保障面板Function OK，无法保障面板RA240hrs高低温测试信赖性。

Preliminary Product Specification

保管單位 Storage	PM
保存年限 Retention Period	3年

C INTERFACE PIN CONNECTION

FPC Pin Assignment:

FPC connector is used for electronics interface. The recommended model is

Pin NO.	Symbol	I/O	Description	Note
1	GND	P	Ground	
2	GND	P	Ground	
3	GND	P	Ground	
4	VDD	P	External main and I/O power supply ; +3.3V	
5	VDD	P	External main and I/O power supply ; +3.3V	
6	VDD	P	External main and I/O power supply ; +3.3V	
7	VDD	P	External main and I/O power supply ; +3.3V	
8	GND	P	Ground	
9	NC	-	Not connect	
10	NC	-	Not connect	
11	NC	-	Not connect	
12	GND	P	Ground	
13	OLV0P	I	LVDS odd data 0-	
14	OLV0P	I	LVDS odd data 0+	
15	GND	P	Ground	
16	OLV1N	I	LVDS odd data 1-	
17	OLV1P	I	LVDS odd data 1+	
18	GND	P	Ground	
19	OLV2N	I	LVDS odd data 2-	
20	OLV2P	I	LVDS odd data 2+	
21	GND	P	Ground	
22	OLVCLKN	I	LVDS odd clk -	
23	OLVCLKP	I	LVDS odd clk +	
24	GND	P	Ground	
25	OLV3N	I	LVDS odd data 3-	
26	OLV3N	I	LVDS odd data 3-	
27	GND	P	Ground	
28	ELV0N	I	LVDS even data 0-	
29	ELV0P	I	LVDS even data 0+	
30	GND	P	Ground	

Preliminary Product Specification

保管單位 Storage	PM
保存年限 Retention Period	3年

31	ELV1N	I	LVDS even data 1-	
32	ELV1P	I	LVDS even data 1+	
33	GND	P	Ground	
34	ELV2N	I	LVDS even data 2-	
35	ELV2P	I	LVDS even data 2+	
36	GND	P	Ground	
37	ELVCLKN	I	LVDS even clk -	
38	ELVCLKP	I	LVDS even clk +	
39	GND	P	Ground	
40	ELV3N	I	LVDS even data 3-	
41	ELV3P	I	LVDS even data 3+	
42	GND	P	Ground	
43	RESET	I	Global reset pin RESET="H",normal operation.(Default) RESET="L",LCM is in reset state.	
44	STBYB	I	Standby mode control. STBYB="H",normal operation. STBYB="L",LCM is in standby state.(Default)	
45	SHLR	I	Horizontal shift direction (source output) selection. RL = "H": Left -> Right(default) RL = "L": Right -> Left	
46	UPDN	I	Vertical shift direction (gate output) selection. TB = "H": Top ->Bottom (default) TB = "L": Bottom->Top	
47	NC	-	Not connect	
48	GND	P	Ground	
49	BIST	I	Enable built-in selftest (BIST)function BIST=H,BIST Mode BIST=L,Normal Mode	
50	NC	-	Not connect	

Preliminary Product Specification

保管單位 Storage	PM
保存年限 Retention Period	3年

D. Optical specifications

Item	Symbol	Condition	Specification			Unit	Remark
			Min.	Typ.	Max.		
Response time	Tr+Tf	$\theta = 0^\circ$	-	20	30	ms	Note2, 25°C
Contrast ratio	CR	$\theta = 0^\circ$	800	1000	-		Note 3
Viewing angle	Top	CR \geq 10	80	85	-	deg.	Note 4
	Bottom		80	85	-		
	Left		80	85	-		
	Right		80	85	-		
Color chromaticity (CF only with OC, light source is C light, CIE 1931)	Wx	$\theta = 0^\circ$	0.291	0.306	0.321	CIE	Note 5 Note 6
	Wy		0.313	0.328	0.343		
Color Gamut (CF only with OC, light source is C light, CIE 1931)	NTSC	CIE1931	73	76	-	%	
White Luminance (Center)	YL	$\theta = 0^\circ$	550	600	-	cd/m ²	

Note 1: Measuring Conditions:

The optical characteristics are determined after the unit has been 'ON' and stable at the maximum brightness, in a dark environment at an ambient temperature at 25°C \pm 2°C.

Note 2 : Definition of response time:

The response time is defined as the LCD optical switching time interval between "White" state and "Black" state. Rise time is the time between photo detector output intensity changed from 10% to 90%. And fall time is the time between photo detector output intensity changed from 90% to 10%.

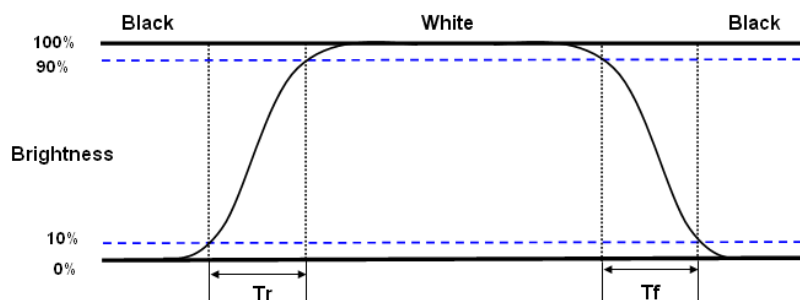

Preliminary Product Specification

保管單位 Storage	PM
保存年限 Retention Period	3年

Note 3: Definition of contrast ratio:

$$\text{Contrast ratio (CR)} = \frac{\text{Luminance measured when LCD on the "White" state}}{\text{Luminance measured when LCD on the "Black" state}}$$

Note 4: Definition of viewing angle

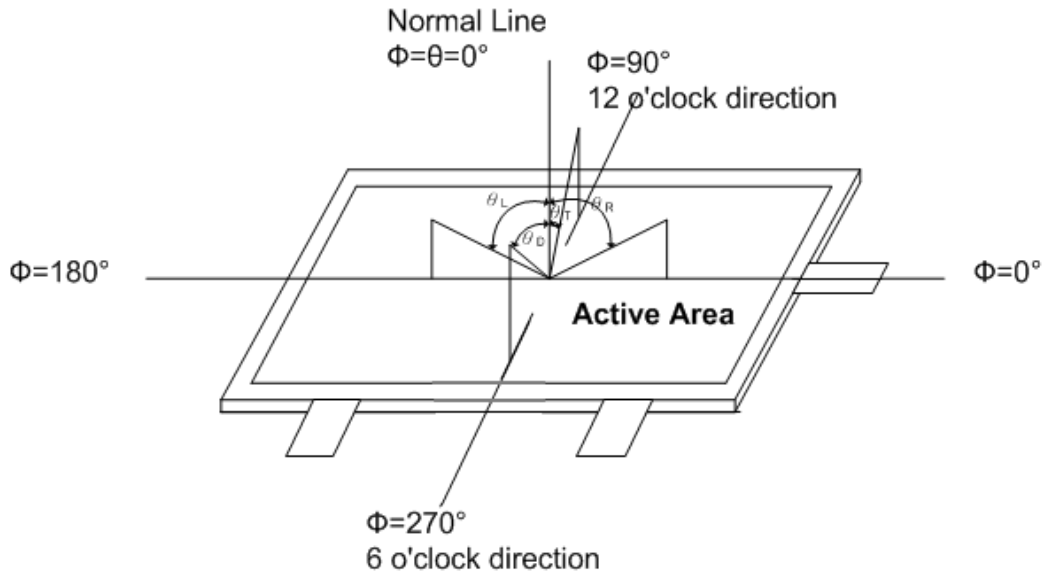

Note 5: Optical characteristic measurement setup.

The LCD module should be stabilized at given temperature for 10 minutes to avoid abrupt temperature change during measuring. In order to stabilize the luminance, the measurement should be executed after lighting Backlight for 10 minutes in a windless room.

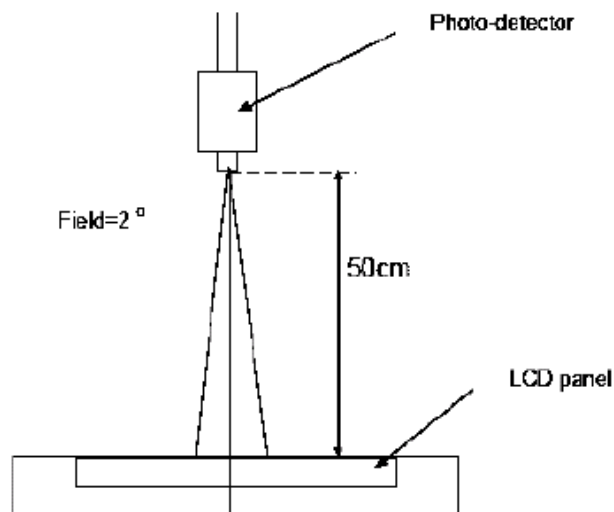

Preliminary Product Specification

保管單位 Storage	PM
保存年限 Retention Period	3年

Note 6: Definition of color chromaticity (CIE1931)

Color coordinates measured at center point of LCD.

Note 7: Measuring Conditions:

The optical characteristics are determined after the unit has been 'ON' and stable at the maximum brightness, in a dark environment at an ambient temperature at $25^{\circ}\text{C} \pm 2^{\circ}\text{C}$. The electrical conditions include $V_{cc} = 3.3\text{ V}$, $f_v = 60\text{ Hz}$. Recommended measuring equipments for luminance and color is BM5A Colorimeter with a viewing cone of 2° or similar. The measuring distance should be about 30-50 cm from the LCD surface at normal unless otherwise specified. The (virtual) measuring spot should be 5mm in diameter. The CIE 1931 Standards shall be used. Viewing angle measurements should be done by the CS2000 EZ Color system or similar.

Note 8:

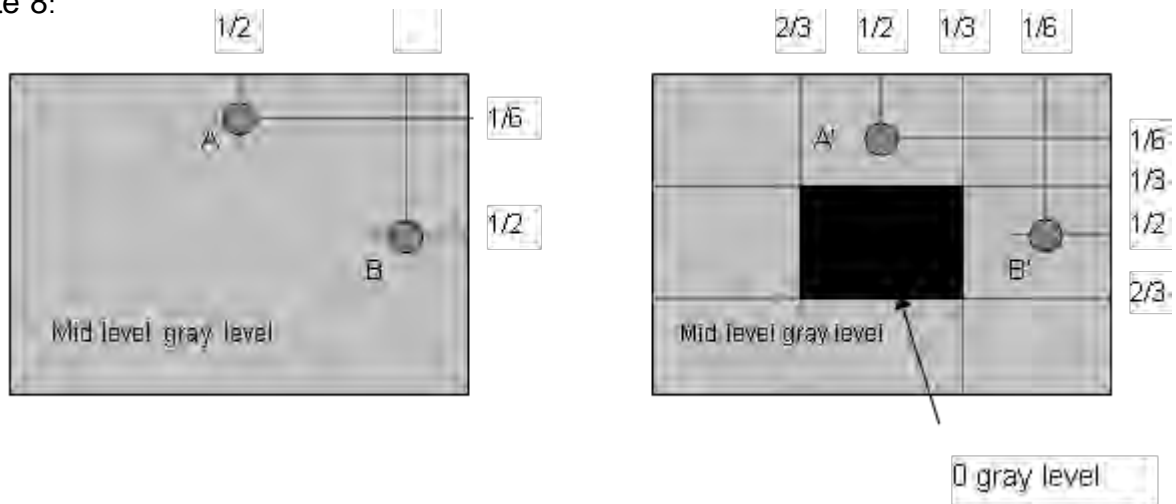

Unit: percentage of dimension of display area

$|L_A - L_{A'}| / L_A \times 100\% = 2\% \text{ max.}$, L_A and $L_{A'}$ are brightness at location A and A'

$|L_B - L_{B'}| / L_B \times 100\% = 2\% \text{ max.}$, L_B and $L_{B'}$ are brightness at location B and B'

Preliminary Product Specification

保管單位 Storage	PM
保存年限 Retention Period	3年

E. Electronic Specification

(1). Typical Operation Conditions

Parameter	Symbol	MIN	TYP	MAX	Unit	Remark
Analog Operating voltage	VCC1	-	3.3	-	V	
Analog Operating voltage	VSP	-	5.5	-	V	
Analog Operating voltage	VSN	-	-5.5	-	V	
Analog Operating voltage	VCOM	-	-1	-	V	
Analog Operating voltage	VGH	-	18.5	-	V	
Analog Operating voltage	VGL	-	-12.5	-	V	

Note1 : Vcom 为理论计算值，与实际面板最佳 Vcom 会有一点偏差，待面板样品调试完毕，将进一步更新。

(2). Reset timing

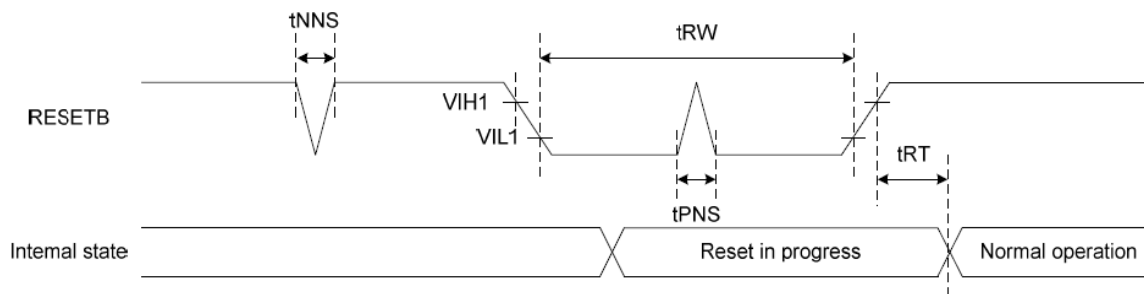

(VCC1=2.7 to 3.6V, GND=0V, TA=-40 to +95°C)

Signal	Paramete	Symbol	Spec.			Unit
			Min.	Typ.	Max.	
RESETB	Reset pulse width	tRW	10	-	-	μs
	Reset complete time	tRT	-	-	5	μs
	Negative spike noise width	tNNS	-	-	100	ns

3.4. Backlight Unit

Item	Symbol	Min	Typ.	Max.	Unit	Note
LED current	IL	-	-	180	mA	(1)(2)(3)
LED voltage	VL	26.1	27.9	29.7	V	(1)(2)(3)
LED life time	Hr	20,000	-	-	Hour	(4)

Note:

(1) Permanent damage may occur to the LCD module if beyond this specification. Functional operation should be restricted to the conditions described under normal operating conditions.

(2) Ta=25±2°C

(3) Backlight LED assignment show as below picture

Preliminary Product Specification

保管單位 Storage	PM
保存年限 Retention Period	3年

(3). Power on / off Sequence

Power On Sequence

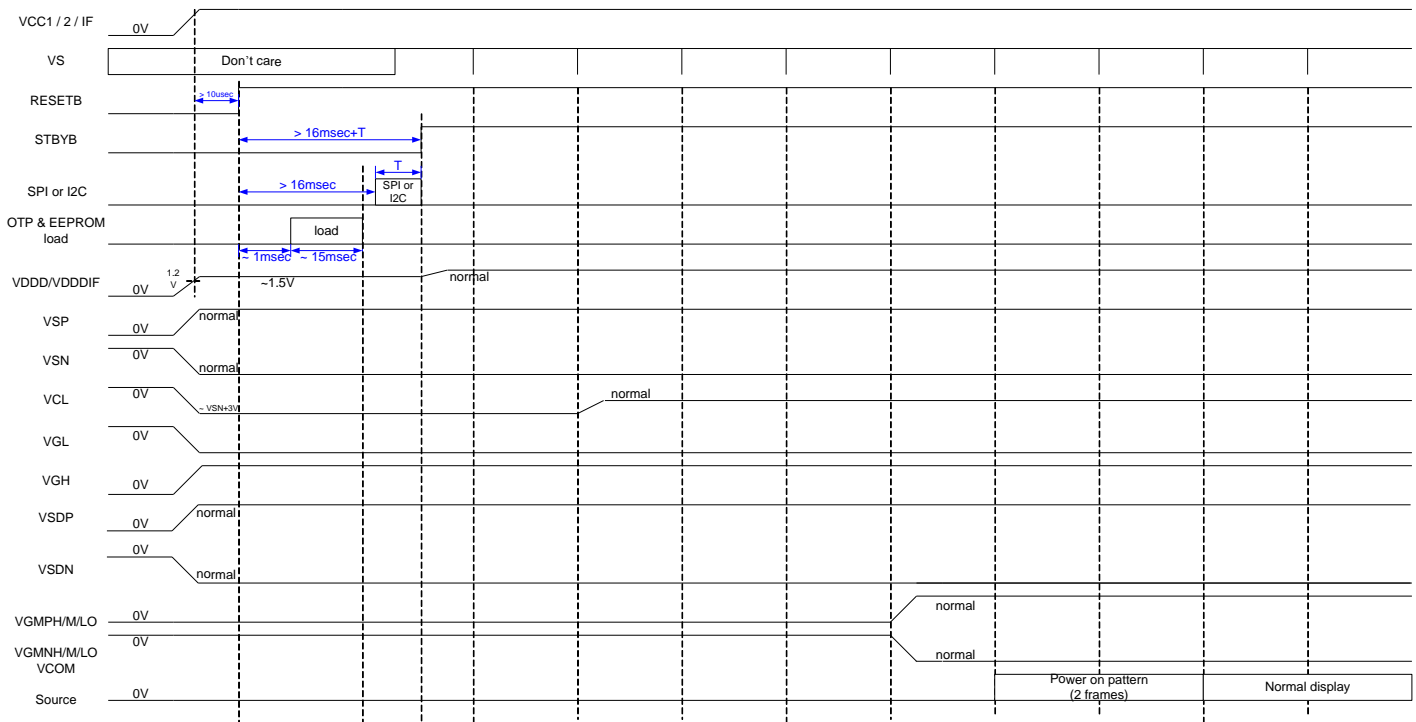

Power Off Sequence

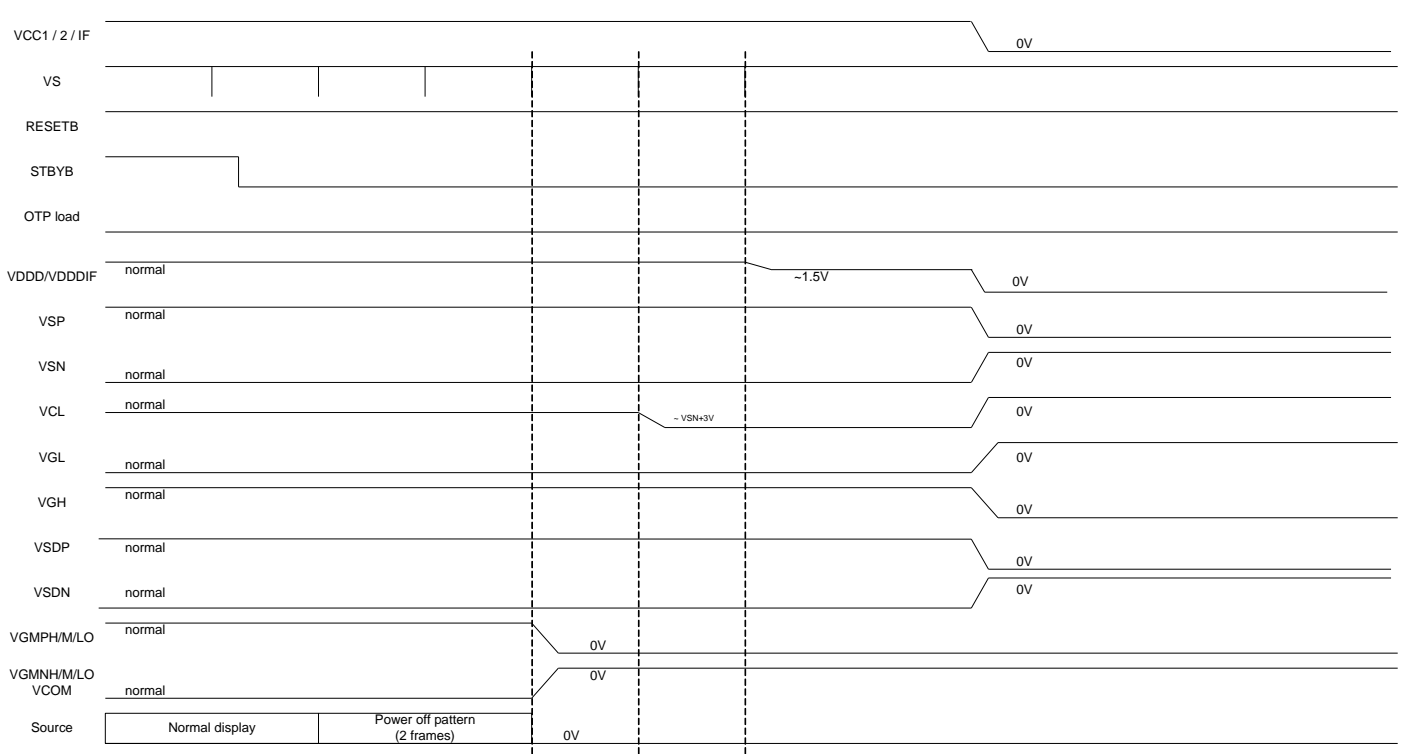

Note: Due to signal recognition delay of external signal, the Power On Sequence may shift 1 VS period.

Preliminary Product Specification

保管單位 Storage	PM
保存年限 Retention Period	3年

(4). Timing Characteristics

LVDS mode DC electrical characteristics

Parameter	Symbol	Condition	Spec.			Unit
			Min.	Typ.	Max.	
Differential input high Threshold voltage	V_{th}	$V_{cm}=1.2V$	+0.15	-	-	V
Differential input low threshold voltage	V_{tl}		-	-	-0.15	V
Differential input common Mode voltage	V_{CM}	-	1	1.2	$1.7- V_{id} /2$	V
LVDS input voltage	V_{INLV}		0.7		1.7	V
Differential input voltage	$ V_{id} $	-	0.15	-	0.6	V
Differential input leakage Current	I_{leak}	-	-10	-	+10	μA

Single-ended:
LVCLKP(R),
LVCLKN(R),
LVD[3:0]P(R),
LVD[3:0]N(R)

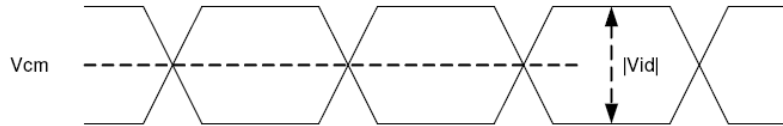

Differential:
LVCLKP(R)-LVCLKN(R),
LVD[3:0]P(R)-
LVD[3:0]N(R)

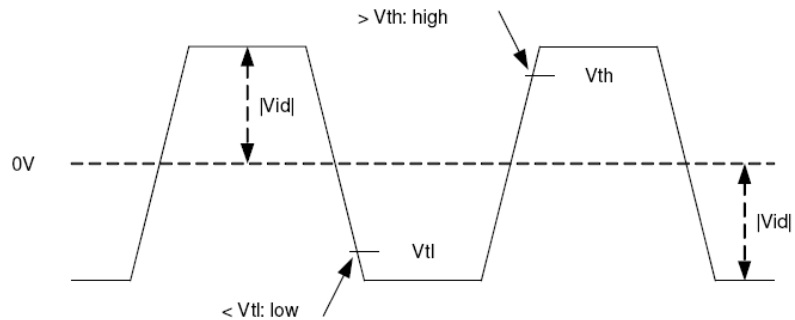

LVDS mode AC electrical characteristics

Parameter	Symbol	Spec.			Unit
		Min.	Typ.	Max.	
Clock frequency	$F_{LV CYC}$	20		85	MHz
Clock period	$T_{LV CYC}$	11.76			ns
1 data bit time	UI		1/7		$T_{LV CYC}$
Clock high time	$T_{LV CH}$		4		UI
Clock low time	$T_{LV CL}$		3		UI
Position 1	T_{POS1}	-0.2	0	0.2	UI
Position 0	T_{POS0}	0.8	1	1.2	UI
Position 6	T_{POS6}	1.8	2	2.2	UI
Position 5	T_{POS5}	2.8	3	3.2	UI
Position 4	T_{POS4}	3.8	4	4.2	UI
Position 3	T_{POS3}	4.8	5	5.2	UI
Position 2	T_{POS2}	5.8	6	6.2	UI
Input eye width	T_{EYEW}	0.6	-	-	UI
Input eye border	T_{EX}	-	-	0.2	UI
LVDS wake up time	T_{ENLVDS}	-	-	150	ms

Preliminary Product Specification

保管單位 Storage	PM
保存年限 Retention Period	3年

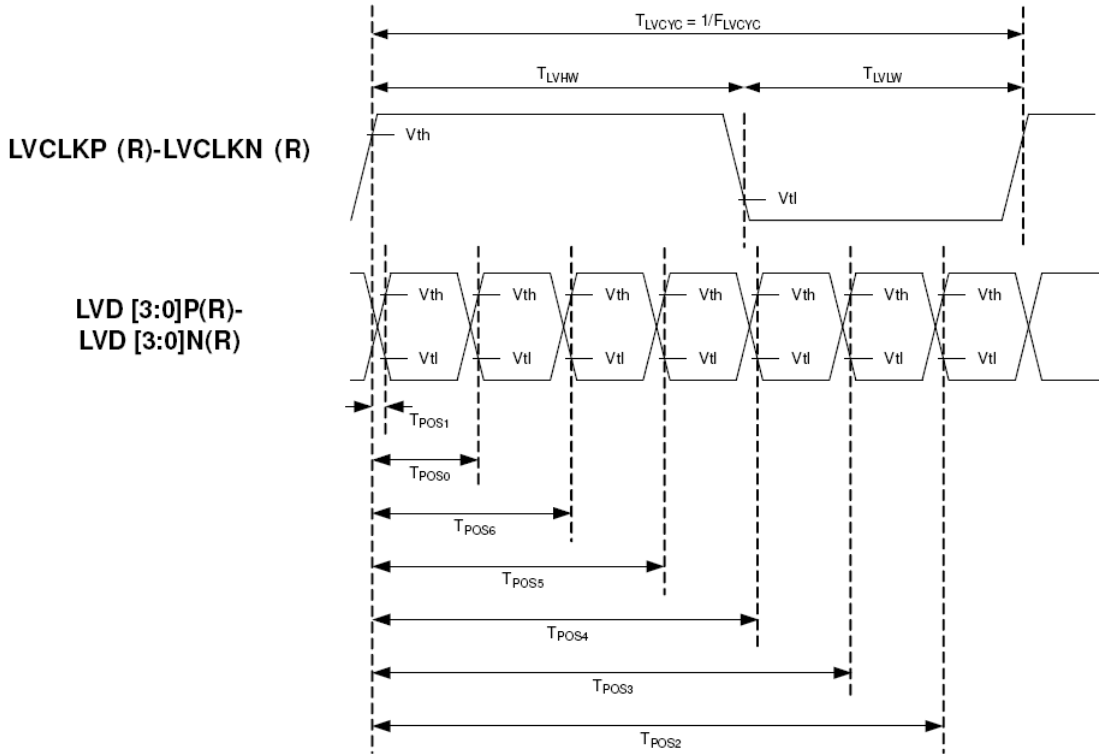

**Single-ended:
LVD [3:0]P,
LVD [3:0]N**

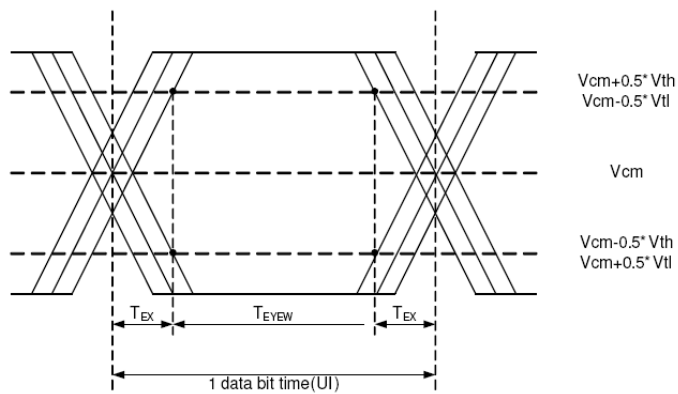

**Differential:
LVD [3:0]P-LVD [3:0]N**

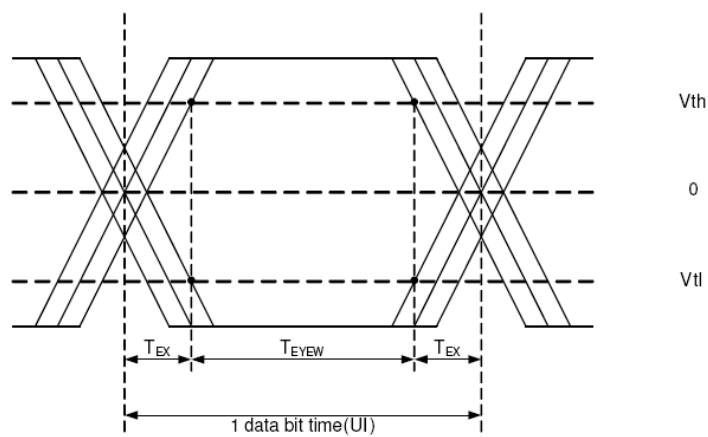

Preliminary Product Specification

保管單位 Storage	PM
保存年限 Retention Period	3年

2-port LVDS signals, VESA format, 8-bit mode

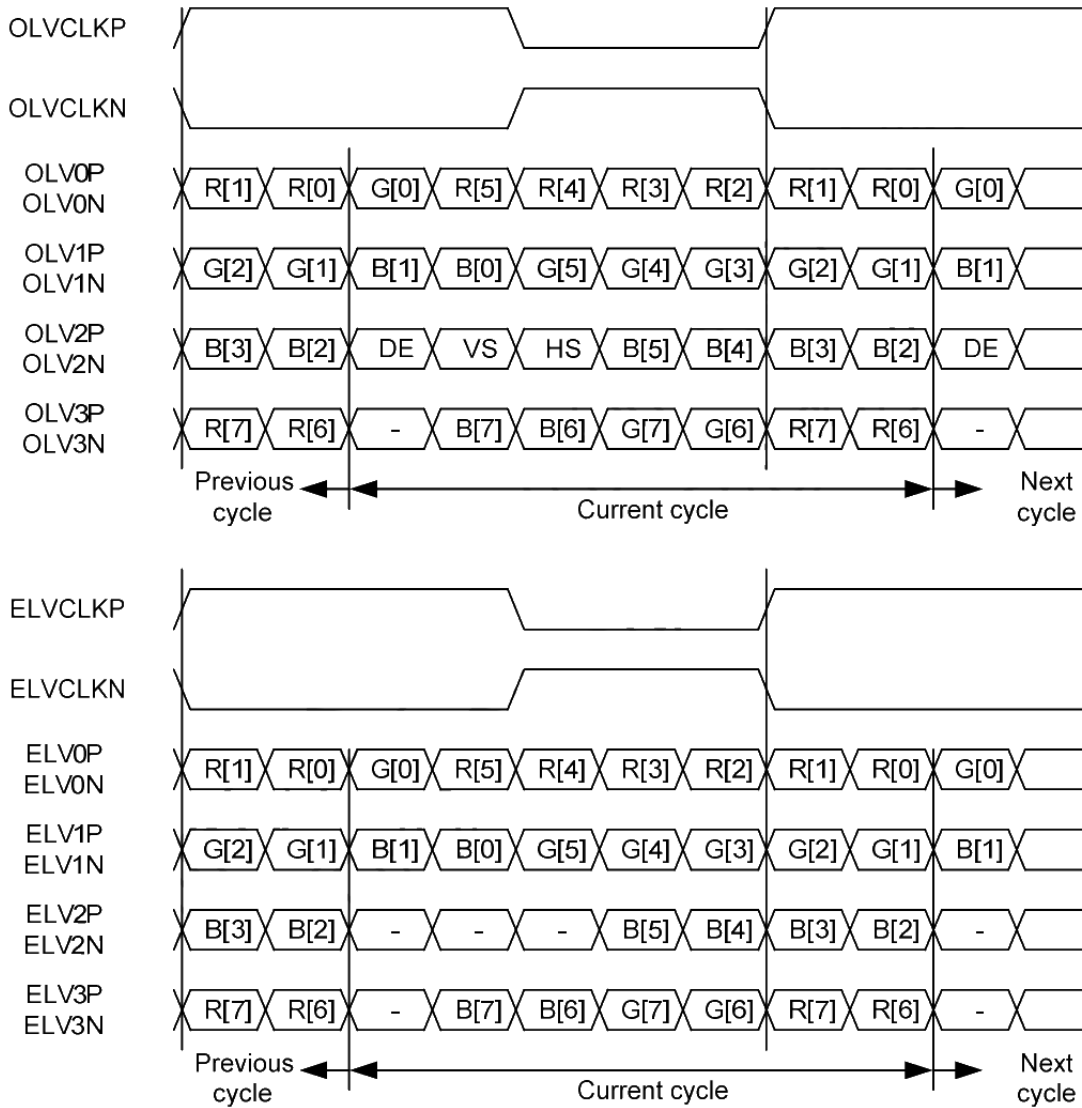

I2C Timing setting

Preliminary Product Specification

保管單位 Storage	PM
保存年限 Retention Period	3年

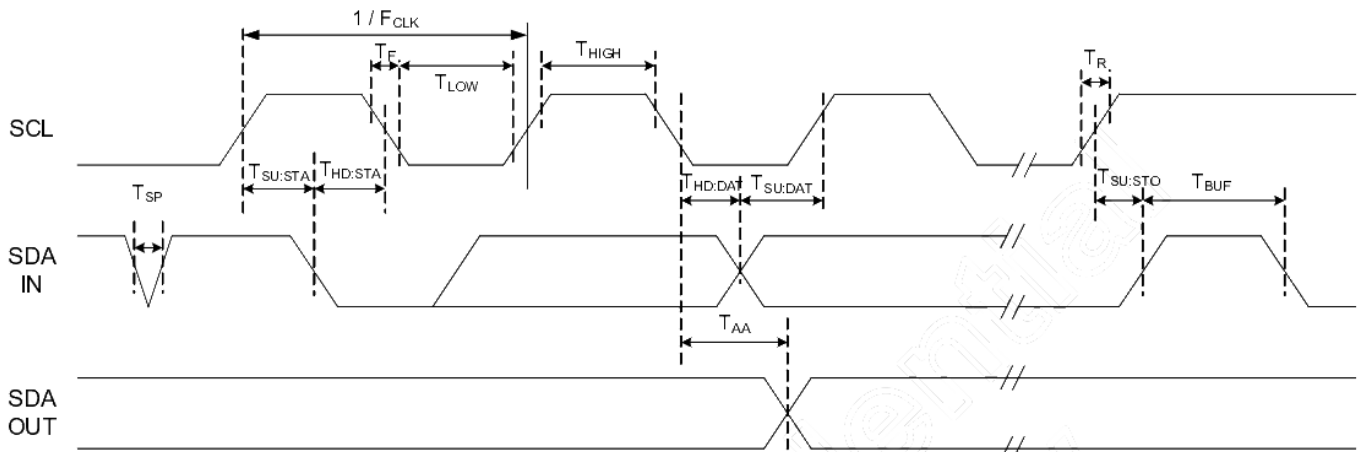

(VCC1=VCC2=VCCIF=2.7V to 3.6V, VSS1=VSS2=VSSA=0V, T_{OP}=-40~95°C)

Parameter	Symbol	Condition	Spec.			Unit
			Min.	Typ.	Max.	
Clock frequency	F _{CLK}	-	-	-	400	KHz
Clock high time	T _{HIGH}	-	600	-	-	ns
Clock low time	T _{LOW}	-	1300	-	-	ns
SDA and SCL rise time	T _R	-	-	-	300	ns
SDA and SCL fall time	T _F	-	-	-	300	ns
Start condition hold time	T _{HD:STA}	-	600	-	-	ns
Start condition setup time	T _{SU:STA}	-	600	-	-	ns
Data input hold time	T _{HD:DAT}	-	0	-	-	ns
Data input setup time	T _{SU:DAT}	-	100	-	-	ns
Stop condition setup time	T _{SU:STO}	-	600	-	-	ns
Output valid from clock	T _{AA}	-	-	-	900	ns
Bus free-time	T _{BUF}	Time the bus must be free before a new transmission can start	1300	-	-	ns
Input filter spike suppression	T _{SP}	SDA and SCL pins	-	-	50	ns

F. Safety

(1) Sharp Edge Requirements

There will be no sharp edges or corners on the cell that could cause injury.

(2) Materials

There will be no carcinogenic materials used anywhere in the cell. If toxic materials are used, they will be reviewed and approved by the responsible CTC Toxicologist.

G. Display quality

The display quality of the color TFT-LCD FOG should be in compliance with the CTC's Incoming inspection standard.

H. Handling precaution

The Handling of the TFT-LCD should be in compliance with the CTC's handling principle standard.



第三视角

RoHS 产品

ISSUE	DATE	DESCRIPTION	REVISER
△0	20200928	首次发行	夏雷

4. Test Point (测试点):

1. Environment Luminance (环境亮度): ≤ 0.1 cd/m²
2. Test Instrument (测试仪器): BM-7
3. Test Distance (测试距离): 500 mm
4. Aperture Diameter (光圈直径): $\phi 7.7(1^\circ)$

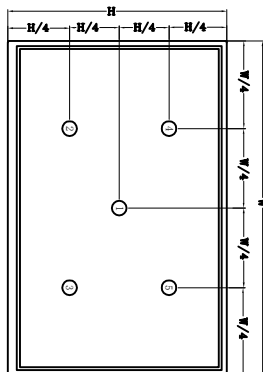

5点测试示意图

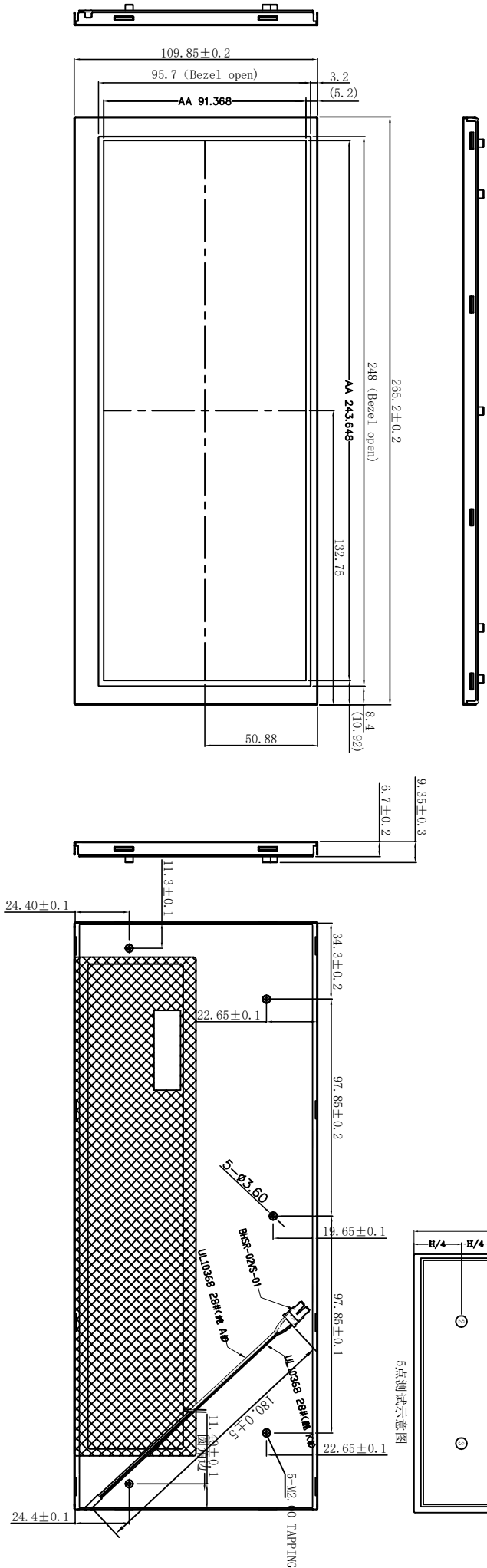

1. Mechanical Outline (Unspecified Tolerances is ± 0.3 mm)

2. Electrical-Optical Characteristics (Ta=25°C)

Item	Symbol	MIN.	TYP.	MAX.	Unit	Condition
Forward Voltage	VF		27.0	29.7	V	定电流 IF=180ma
Dominant Wave Length	X	0.26	0.30	0.34		
	Y	0.26	0.30	0.34		
Uniformity	Avg	75			%	
Module Luminance	Lv	550	600		cd/m ²	

3. Circuit Diagram(LED SMT 9*3=27 PCS)
Color:WHITE

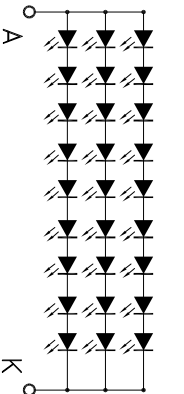

TFT液晶模组

TYPE	DITTING MODE	DATE
CUSTOM NO		A2
CUSTOM MODEL	ER-TFT103-1	EDITION
CUST Drawing	UNIT	MM
	SCALE	1:1
	PAGE	1/1
DATE	APPROVED	20200928

Preliminary Product Specification

保管單位 Storage	PM
保存年限 Retention Period	3年

I. Reliability Assurance Specification

Test Item	Test Condition	Judgment	Remark
High Temp. Storage	80°C, 120hrs, Storage	NOTE 1	NOTE 2 NOTE 3 NOTE 4
Low Temp. Storage	-30°C, 120hrs, Storage	NOTE 1	
High Temp. Operation	70°C, 120hrs, Operating	NOTE 1	
Low Temp. Operation	-20°C, 120hrs, Operating	NOTE 1	
Thermal Shock Test	-20oC(0.5hrs)<=>70oC(0.5hrs)200cycles	NOTE 1	
High Temp& Hum Operation	60°C, 90%RH, 120hrs, Operating	NOTE 1	
Image sticking	65°C IS pattern 2hr->RT L127, check 5min	NOTE 6	NOTE 6

Note1: Criteria: Normal display image with no function defect and no line defect. Mura defect Judged by 5% ND filter.

Note2: All tests above are practiced at module type.

Note3: All the cosmetic specification is judged before the reliability stress. Only a single item of these tests shall be executed on a single panel , no more one test item shall be executed on a single panel.

Note4: Evaluation should be tested after storage at room temperature for more than two hours.

Note5: ClassB: Temporary degradation or loss of function or performance which is self-recoverable.

Note6: a. The IS must be disappeared by 5% ND Filter.

b. After 5min , IS can't be seen by human eyes.