

USB

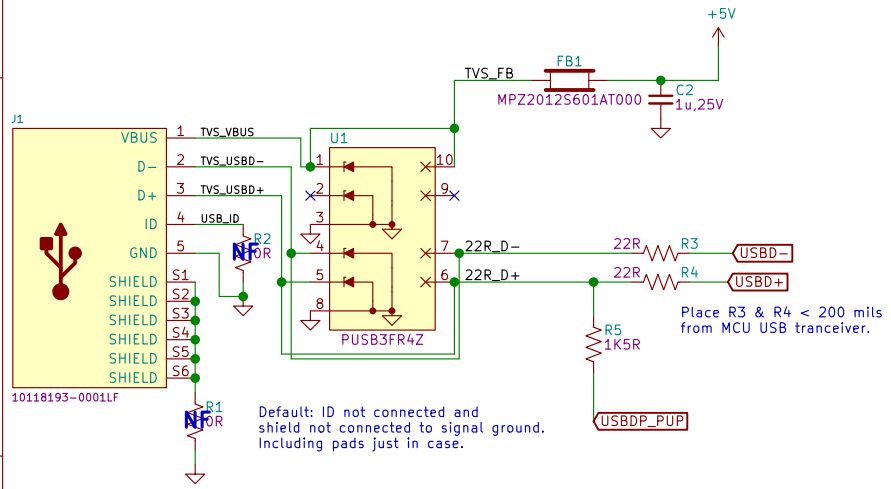

+3V3 LDO

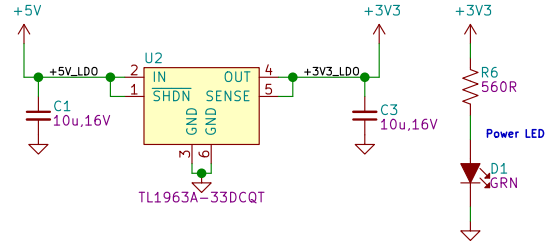

STM32F103XX

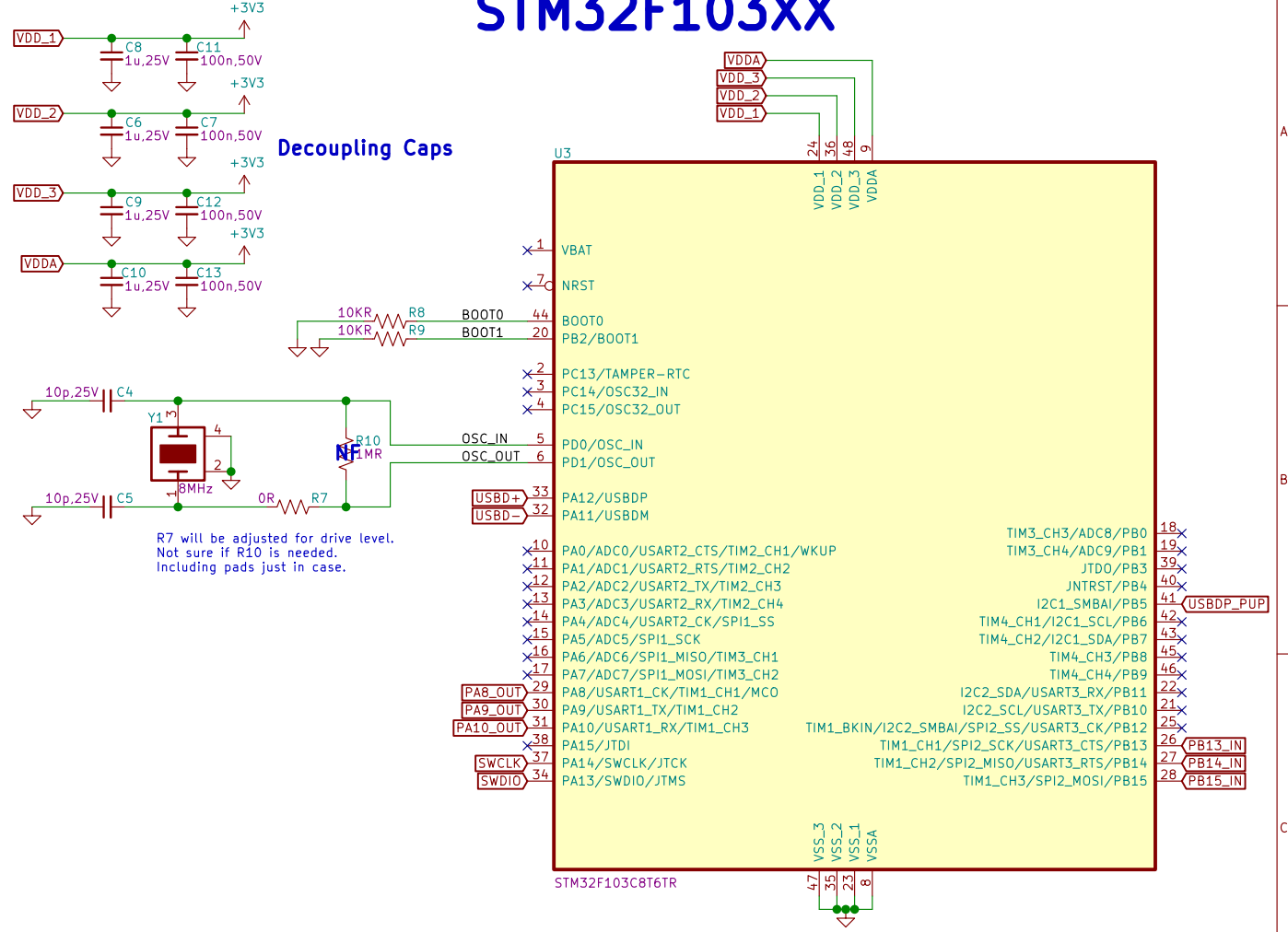

3x3 Key Matrix

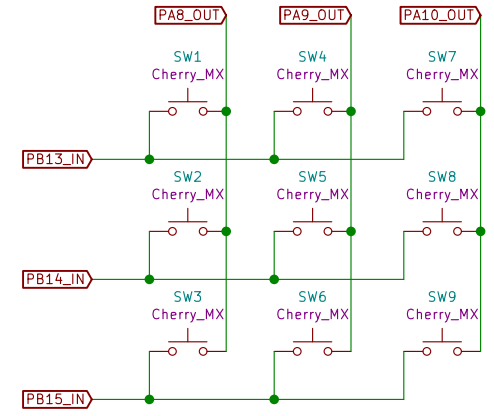

Debug/Program Interface

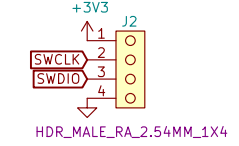

M2 Mounting Holes

