

Title: <b>Power</b>		
Project: <b>STM32L4R9I-DISCO</b>		
Size: <b>A4</b>	Reference: <b>MB1311</b>	Revision: <b>C</b>
Date: <b>28/08/2017</b>	Sheet: <b>2</b> of <b>14</b>	



**WARNING: Some Arduino IOs are shared with other functions:**

Following ARD signals are multiplexed or shared with other functions. In case ARDUINO UNO is connected, take care that the corresponding features are disconnected or well configured :

- ARD\_D7 : DCML\_HSYNC/DE (Camera conflict)
- ARD\_A5 : STMOD+\_PWM (STMod+ / PMOD conflict)
- ARD\_D15 : I2C3\_SCL (shared with STMod+)
- ARD\_D14 : I2C3\_SDA (shared with STMod+)
- ARD\_D13 : DSI\_SPI2\_SCK (SPI2\_SCK shared with STMod+/PMOD and DSI option)
- ARD\_D12 : DSI\_SPI2\_CX (SPI2\_MISO shared with STMod+/PMOD and DSI option)
- ARD\_D11 : DSI\_SPI2\_MOSI (SPI2\_MOSI shared with STMod+/PMOD and DSI option)

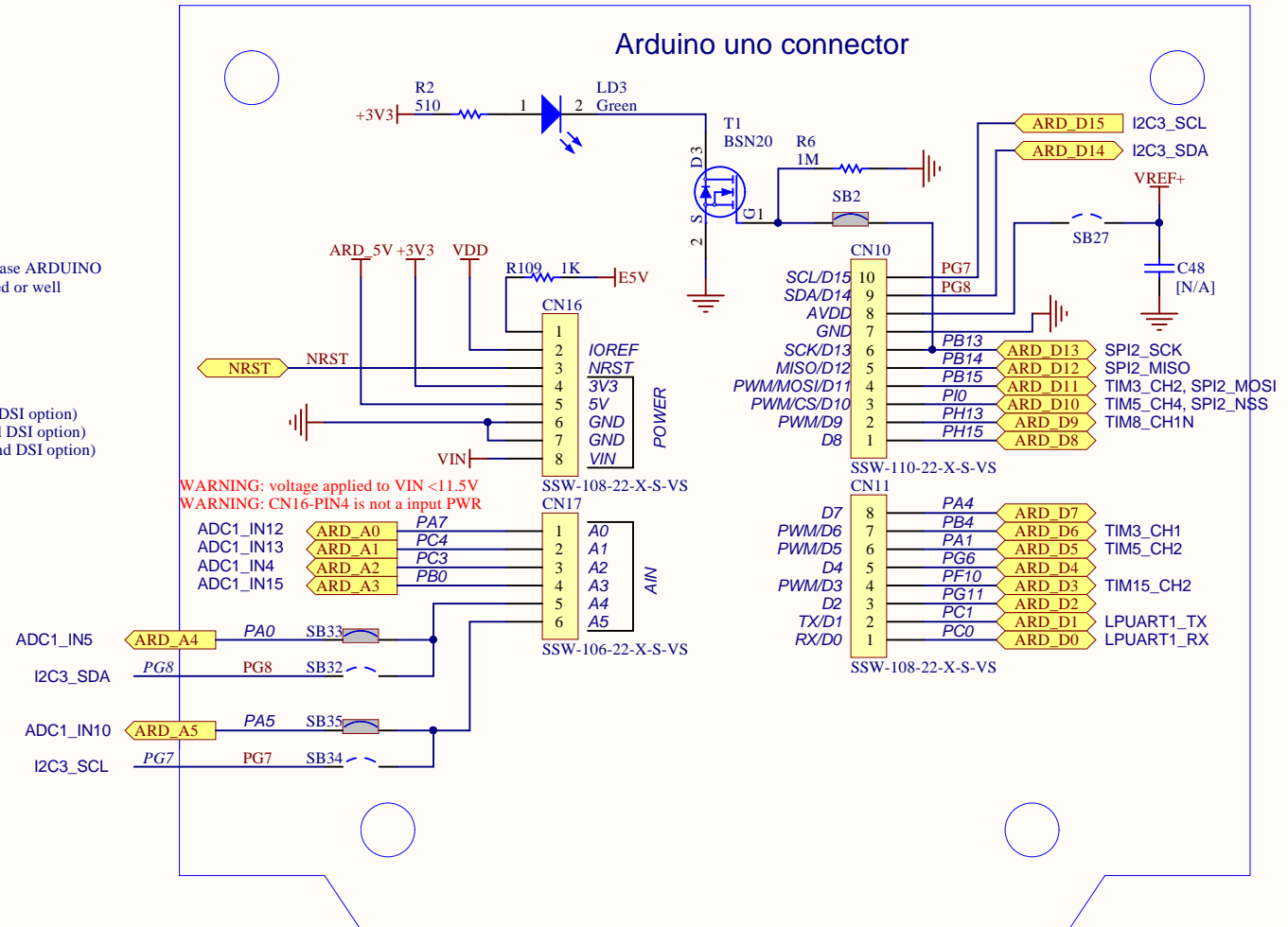

Title: <b>Arduino Uno connector</b>		
Project: <b>STM32L4R9I-DISCO</b>		
Size: A4	Reference: MB1311	Revision: C
Date: 28/08/2017	Sheet: 3 of 14	



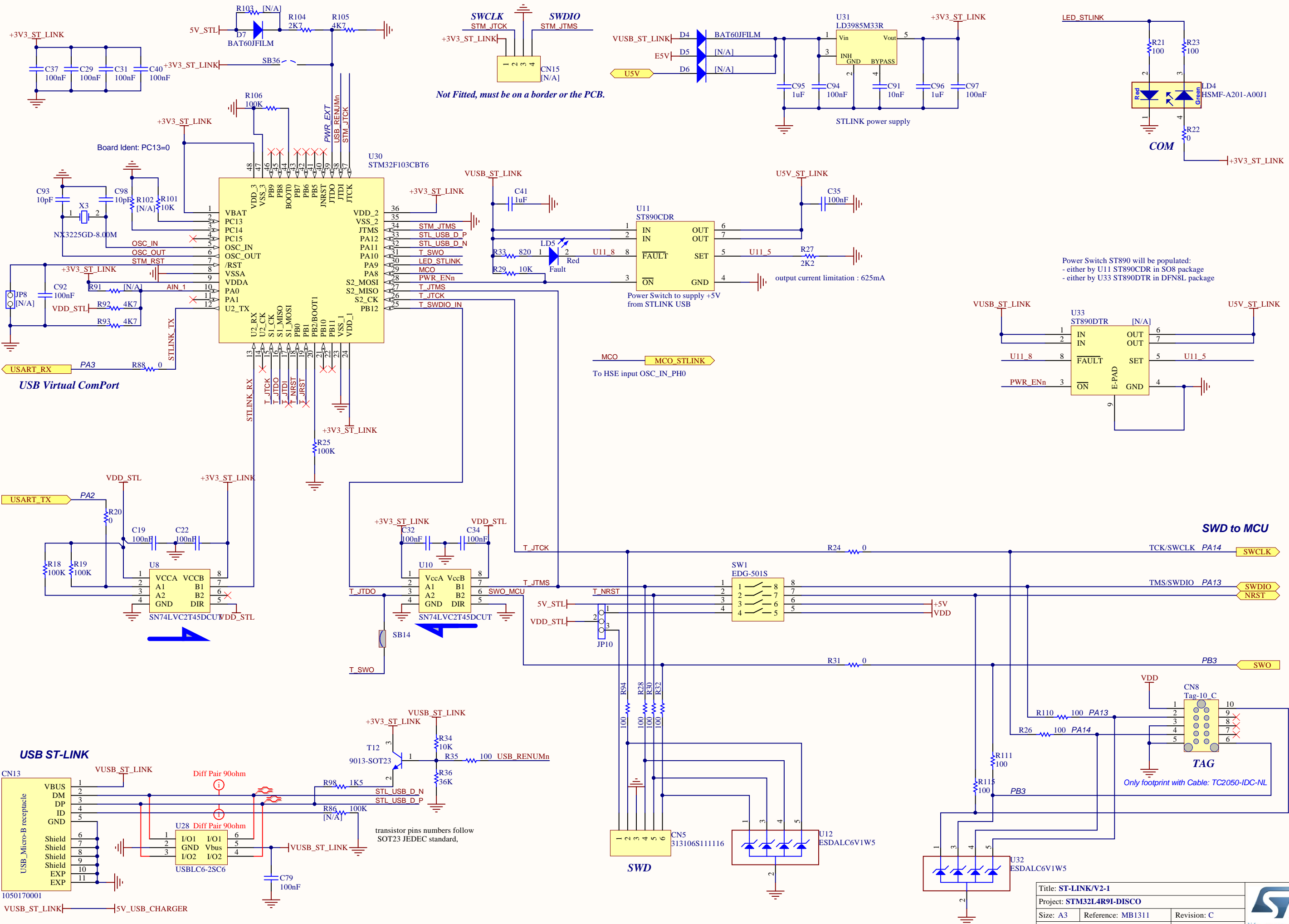

Not Fitted, must be on a border of the PCB.

STLINK power supply

Power Switch ST890 will be populated:  
 - either by U11 ST890CDR in SO8 package  
 - either by U33 ST890DTR in DFN8L package

Power Switch to supply +5V from STLINK USB

MCO → MCO\_STLINK  
 To HSE input OSC\_IN\_PH0

SWD to MCU

Only footprint with Cable: TC2050-IDC-NL

# Macronix MX25LM51245GXD100 used by default (functional at 3V3 only)

ECS feature can be monitored on Macronix by soldering SB25

RESET pins of Flash have internal pull-up (both) by default

Double footprint to be compatible with Micron P/N

VPP connection is accessible on Micron

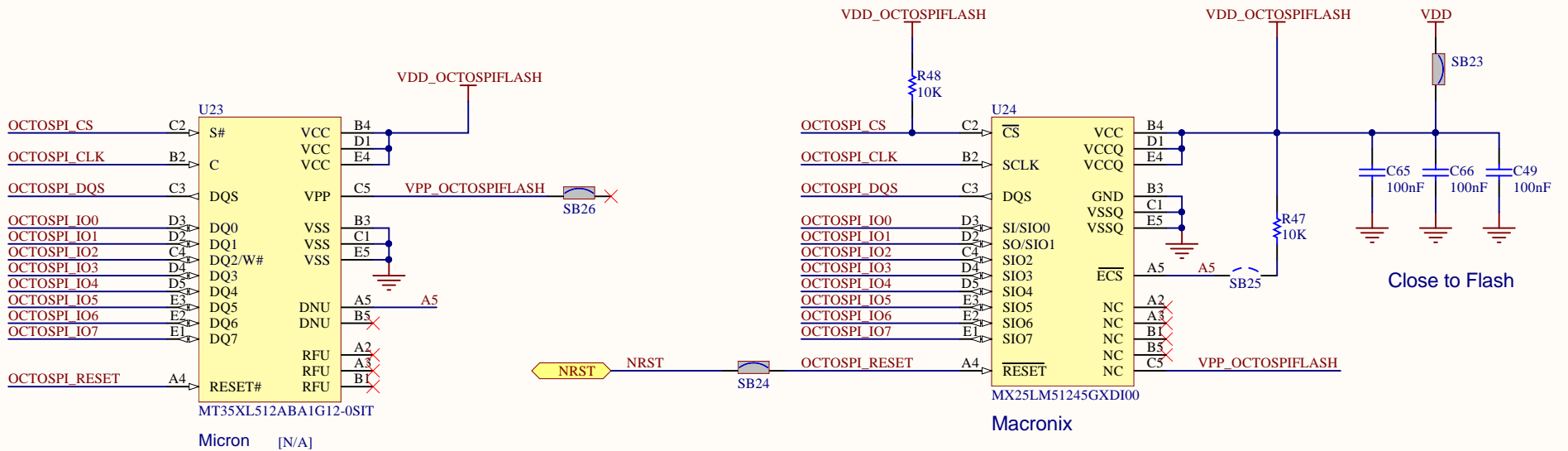
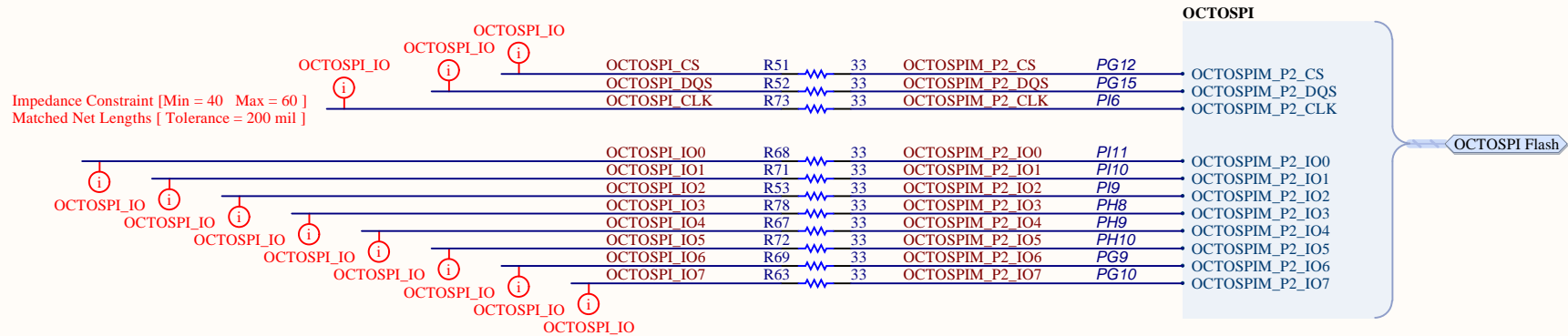

Title: <b>OCTOSPI Flash</b>		
Project: <b>STM32L4R9I-DISCO</b>		
Size: <b>A4</b>	Reference: <b>MB1311</b>	Revision: <b>C</b>
Date: <b>28/08/2017</b>	Sheet: <b>5</b> of <b>14</b>	



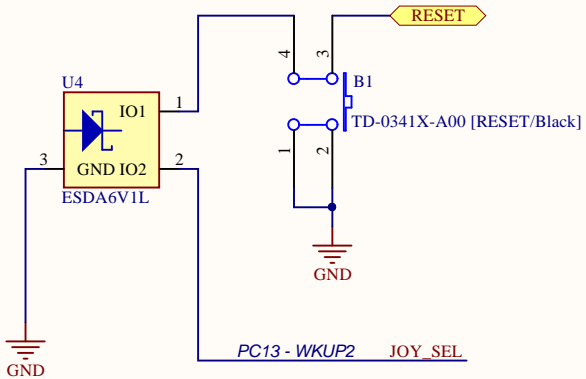

Reset Button

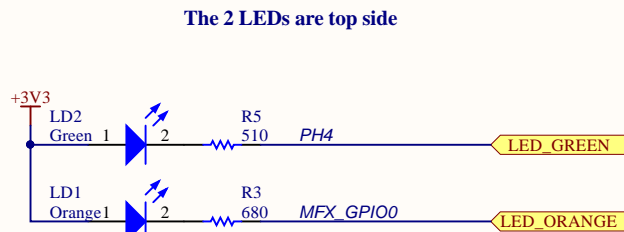

User LEDs

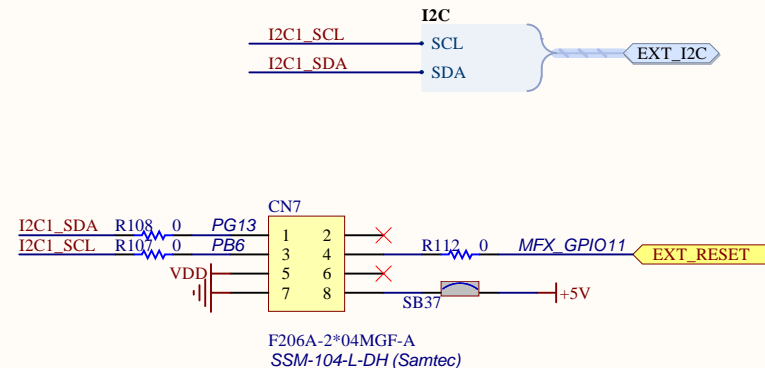

EXT\_I2C Connector

### MICRO SD (TF) Card

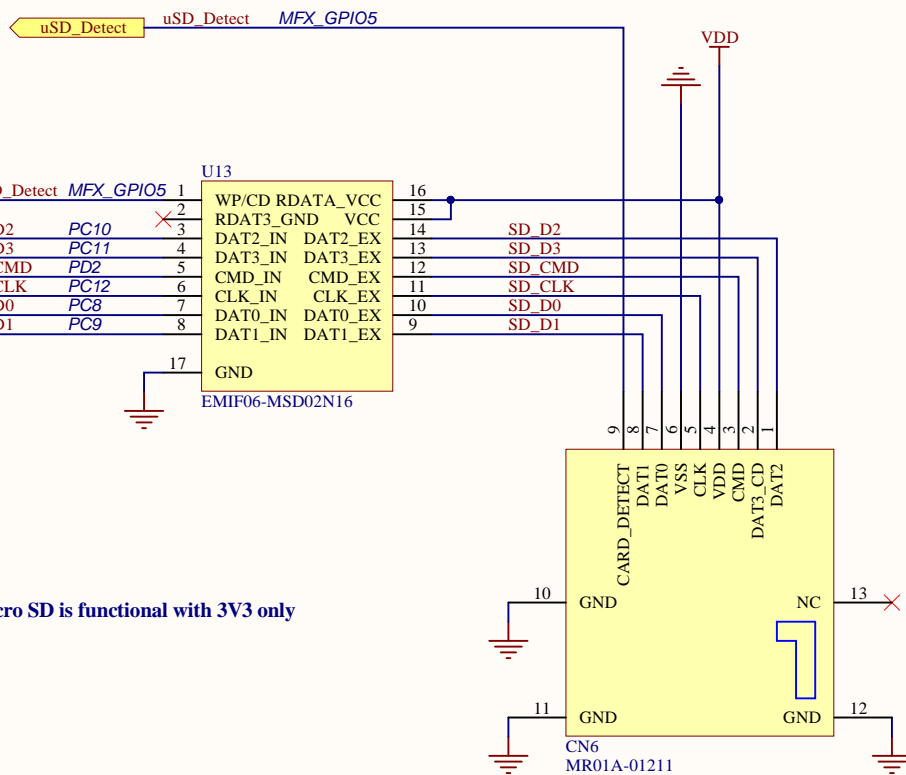

### JOYSTICK

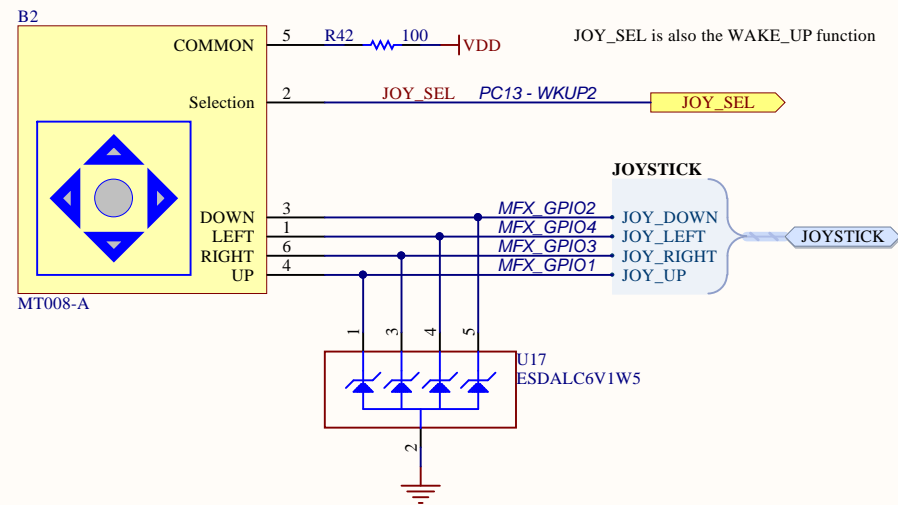

Title: Peripherals		
Project: STM32L4R9I-DISCO		
Size: A4	Reference: MB1311	Revision: C
Date: 28/08/2017	Sheet: 6 of 14	



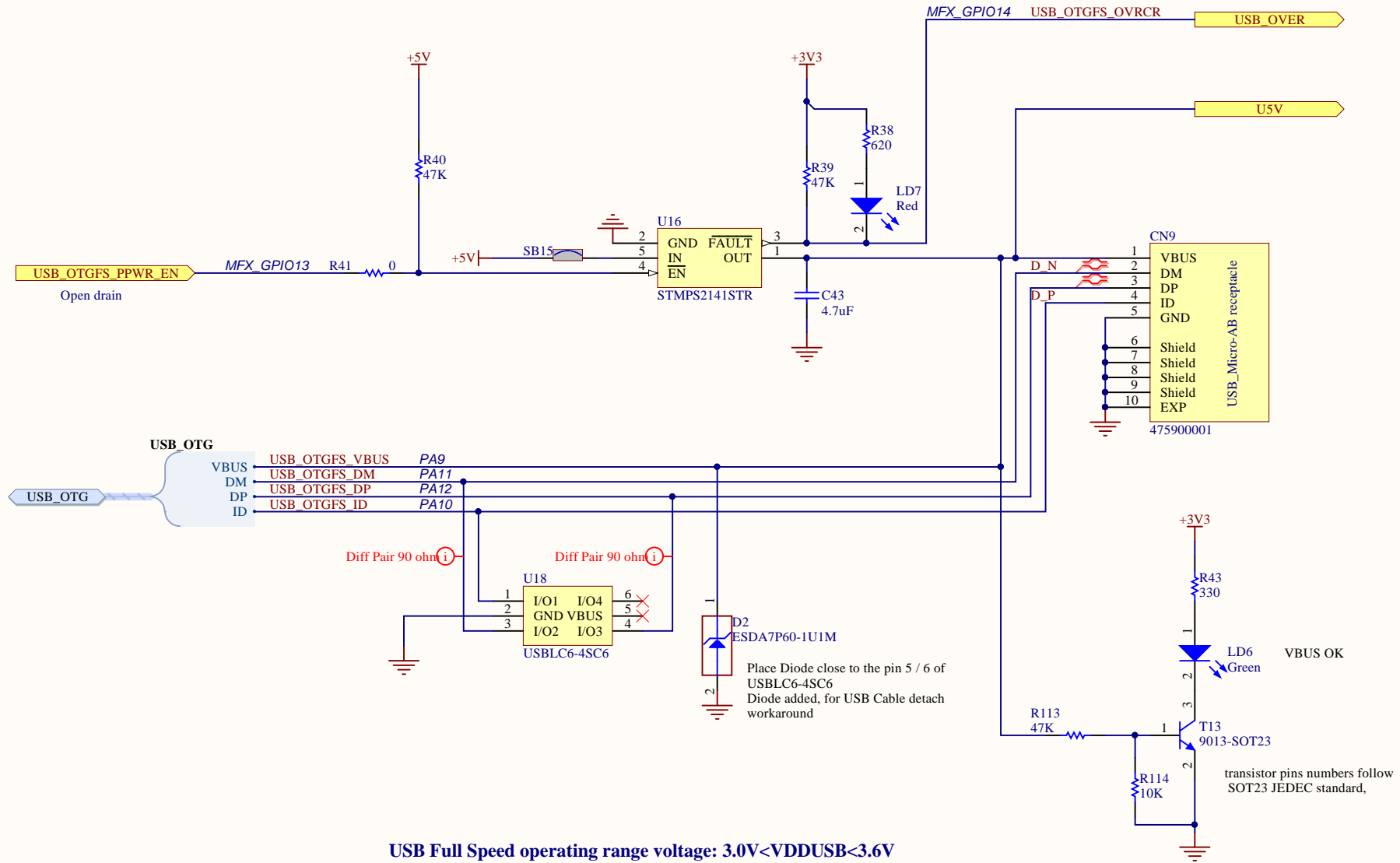

Title: <b>USB_OTG_FS</b>		
Project: <b>STM32L4R9I-DISCO</b>		
Size: <b>A4</b>	Reference: <b>MB1311</b>	Revision: <b>C</b>
Date: <b>28/08/2017</b>	Sheet: <b>7</b> of <b>14</b>	



# DSI LCD

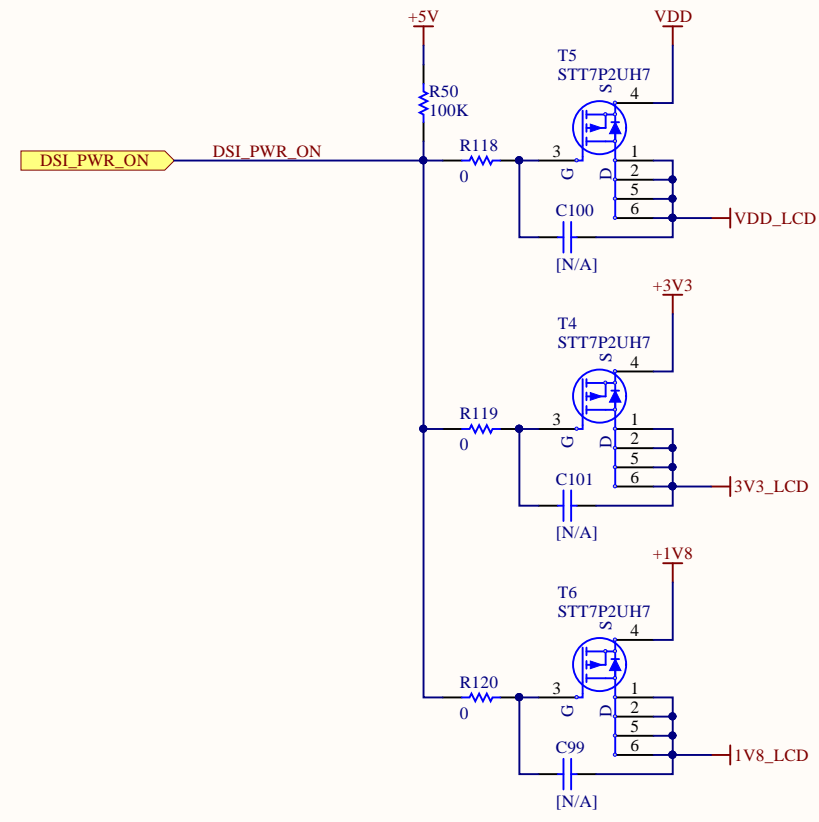
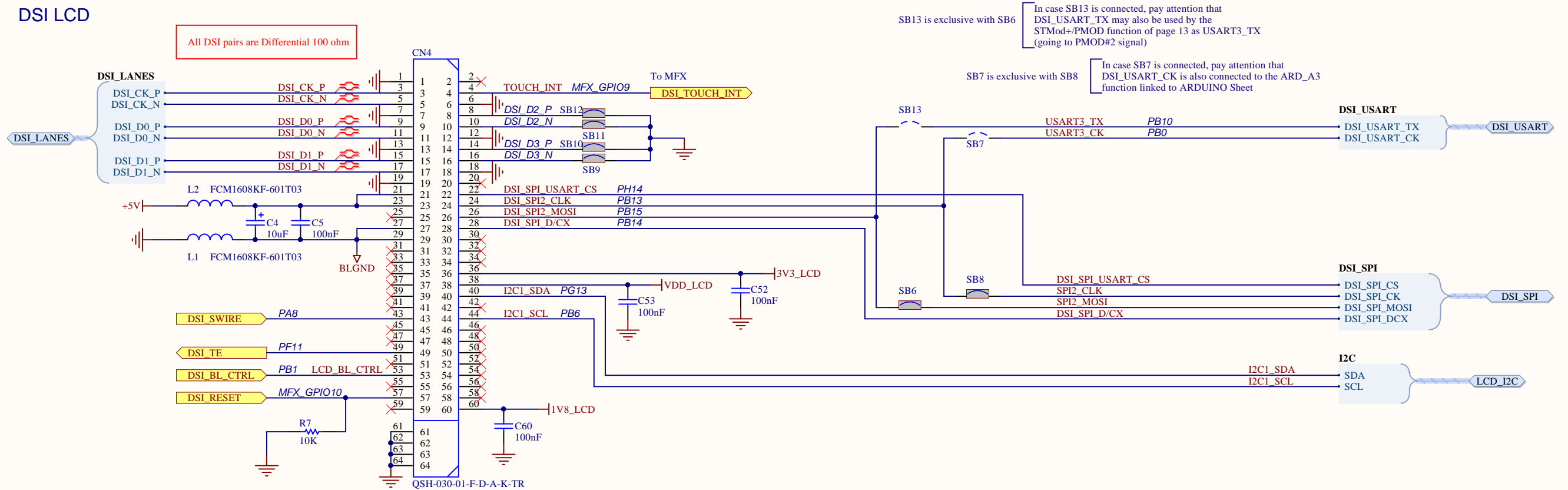



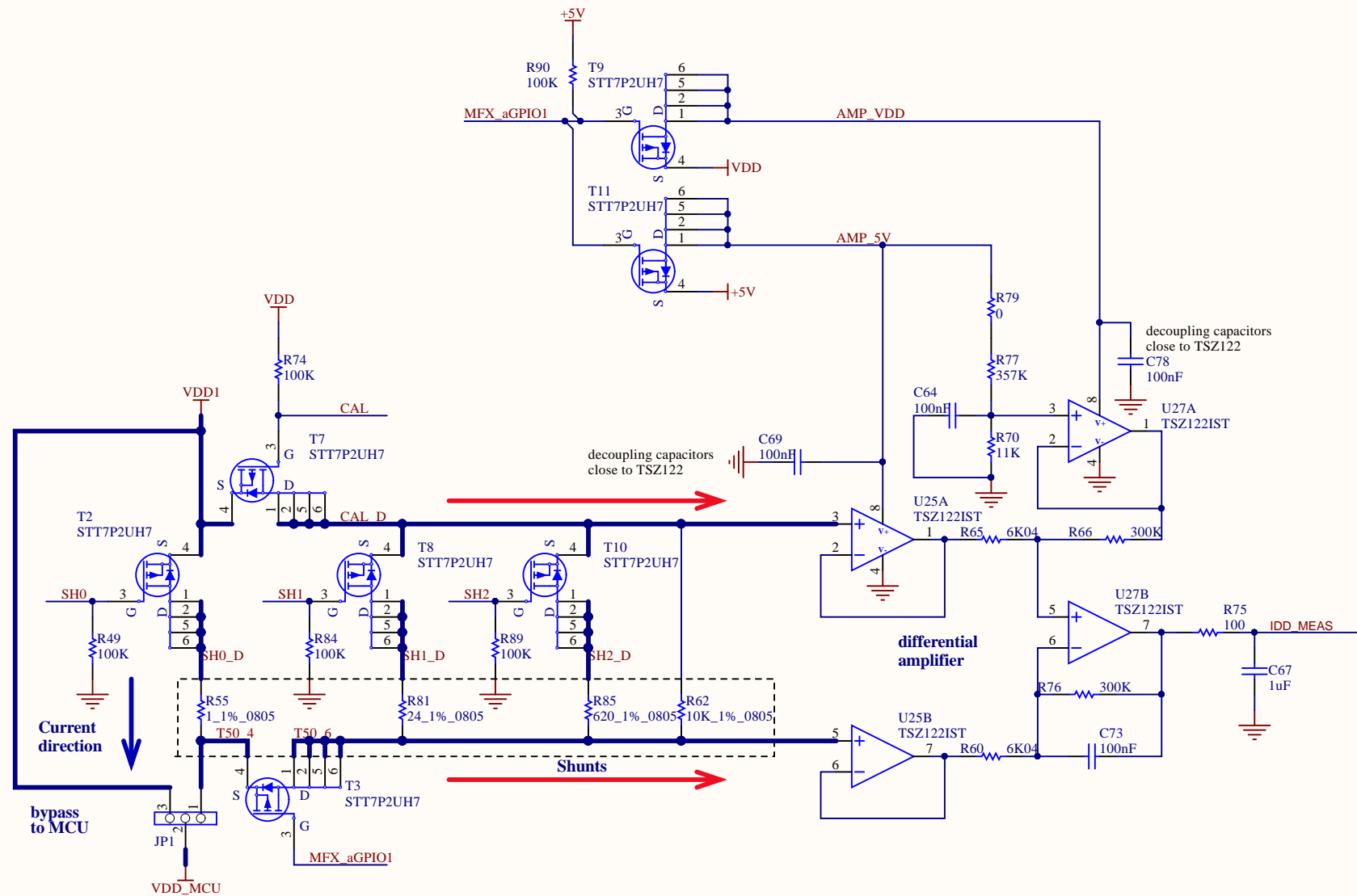
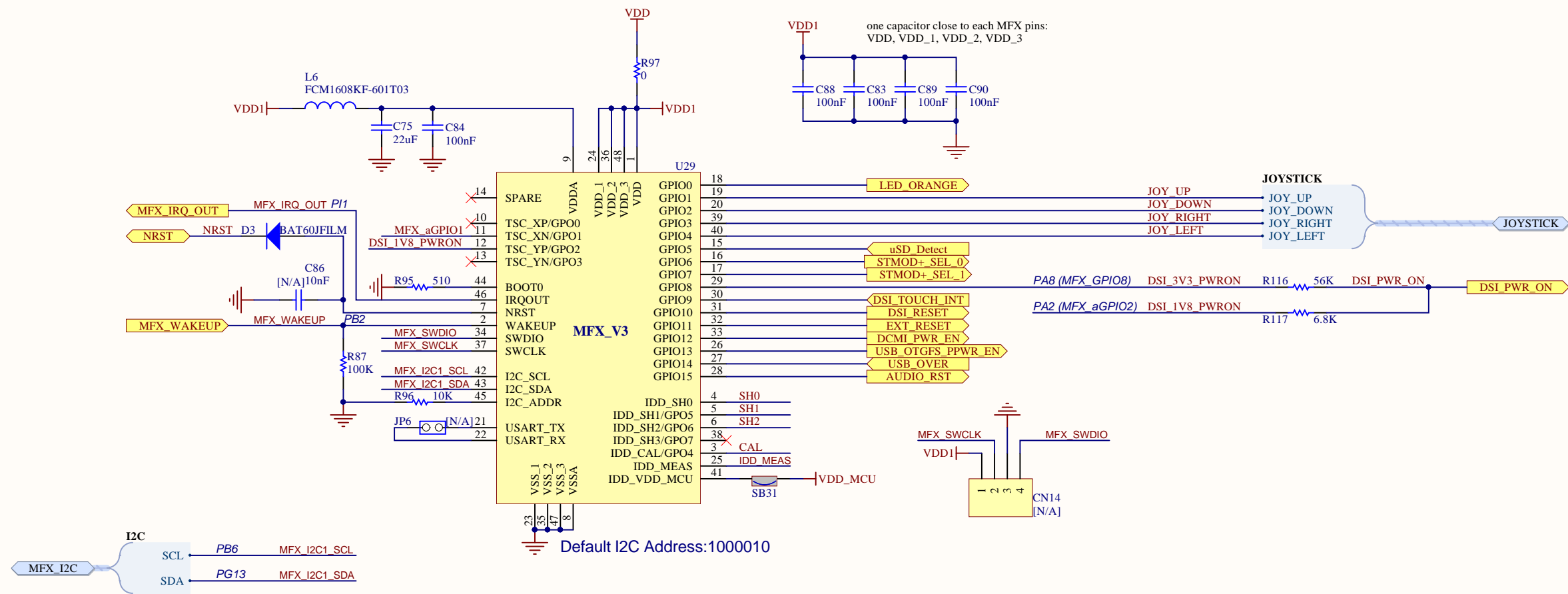

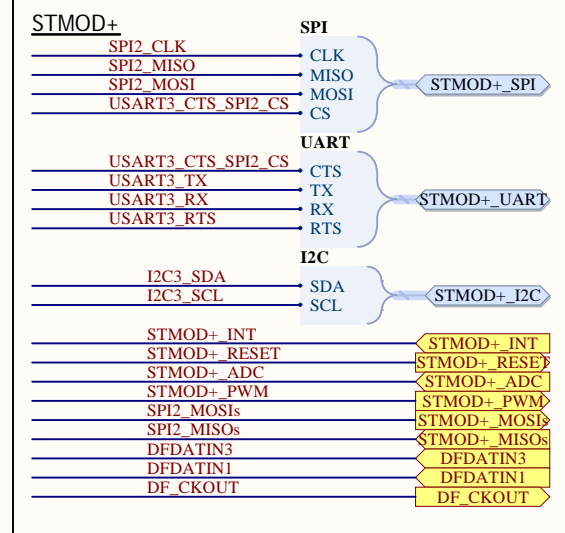
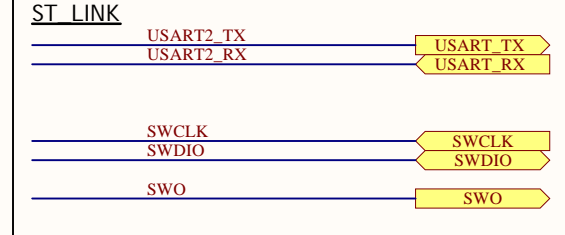
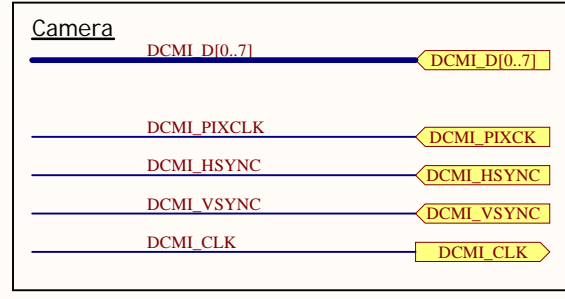
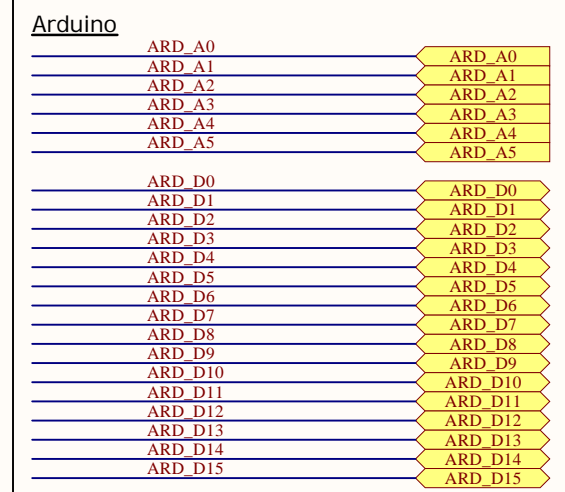
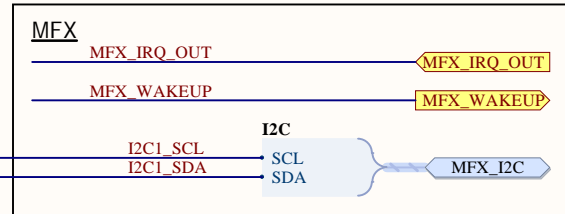
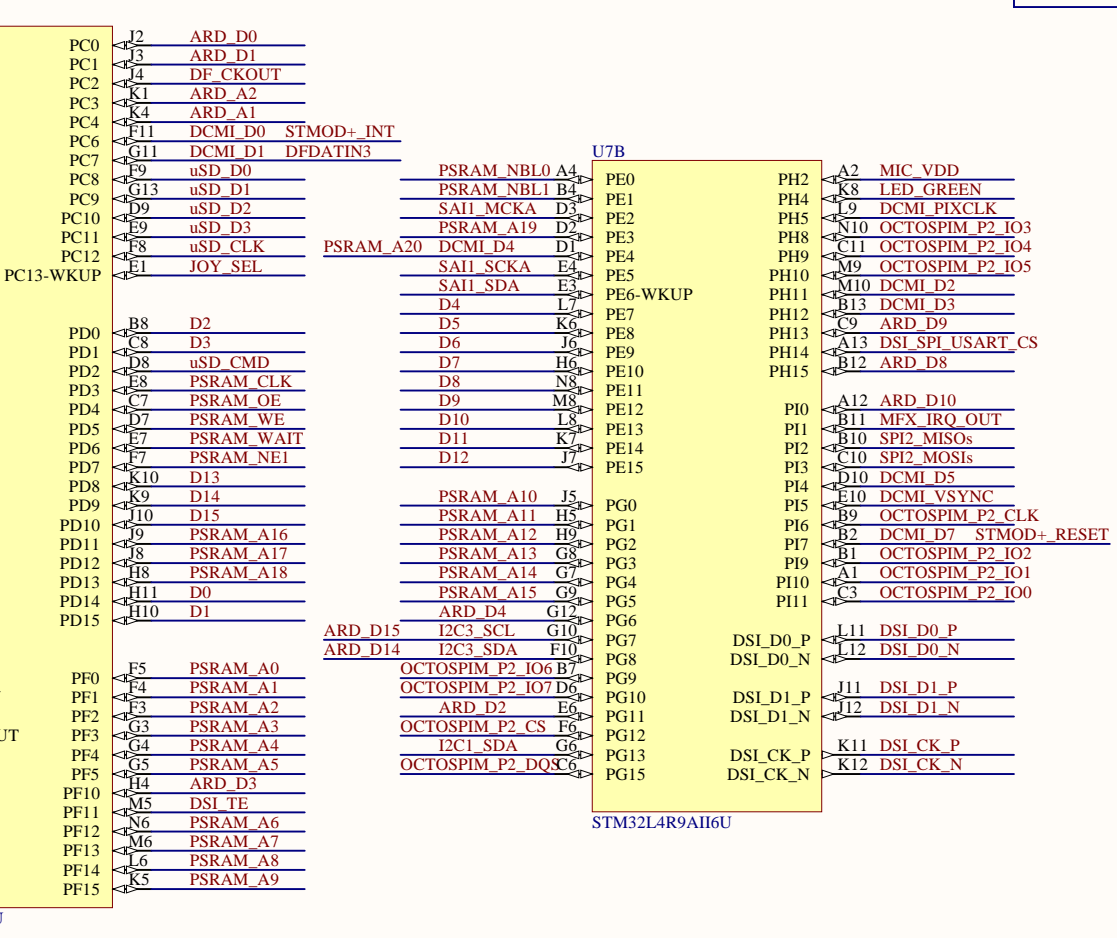
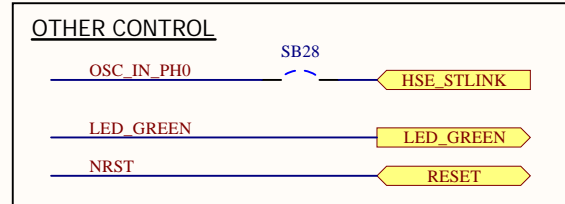
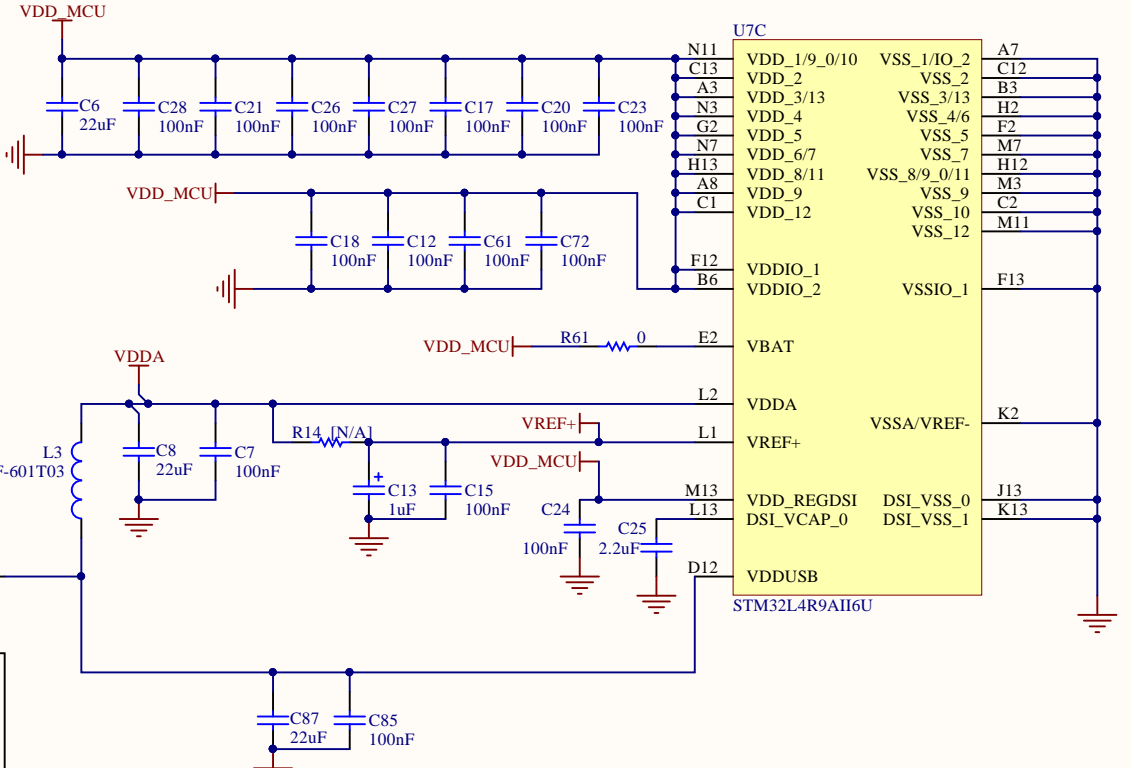
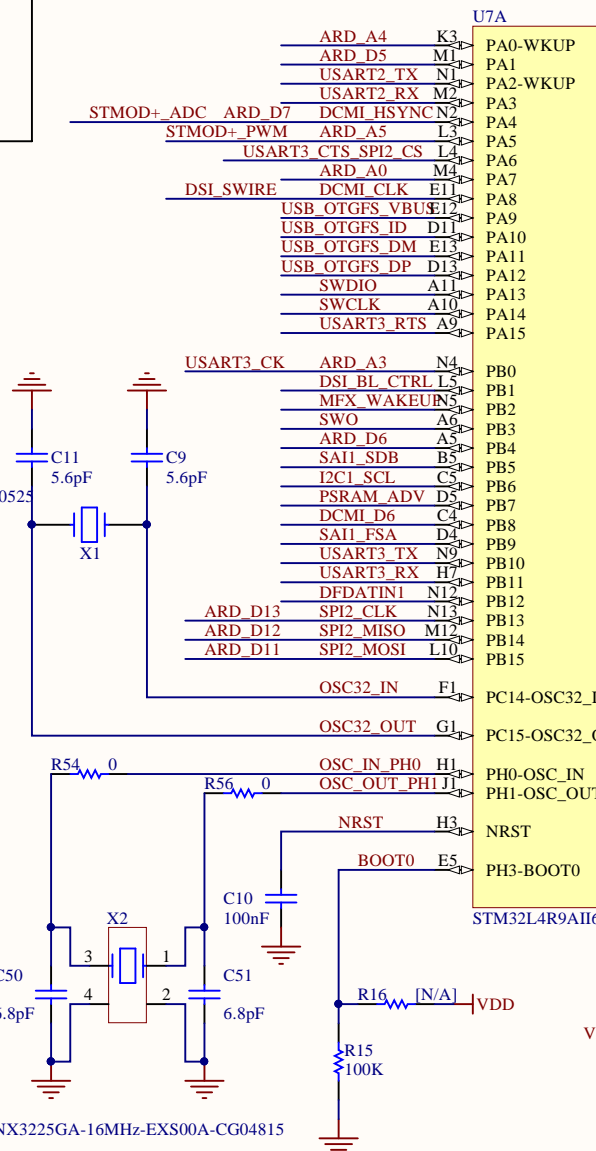
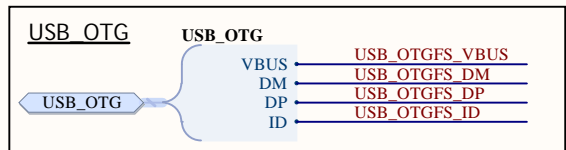
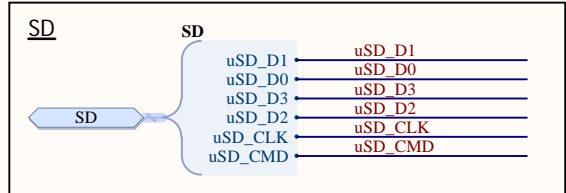
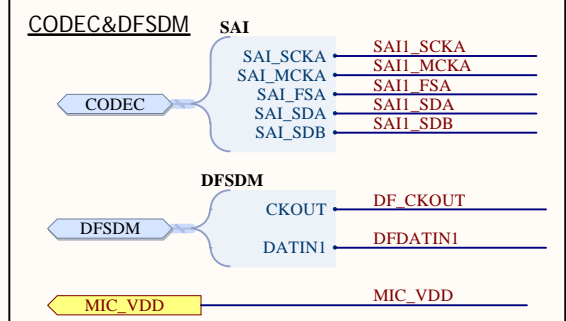
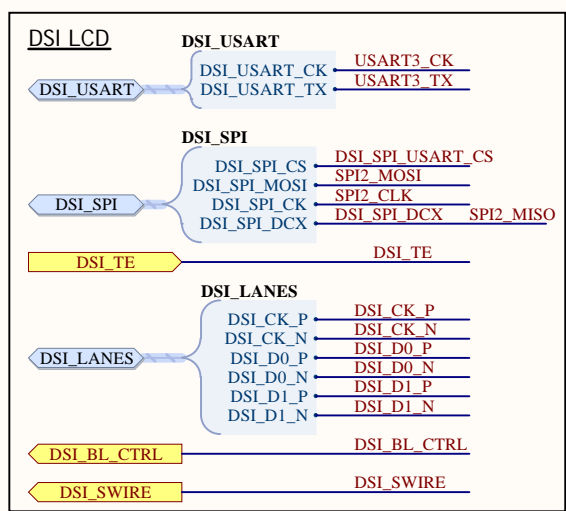
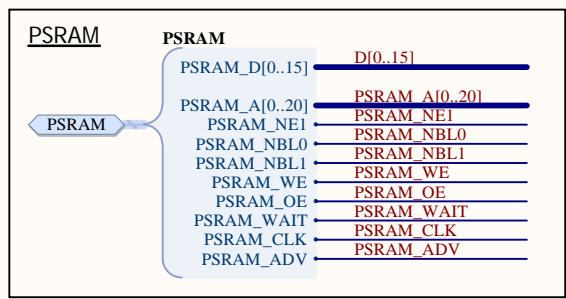
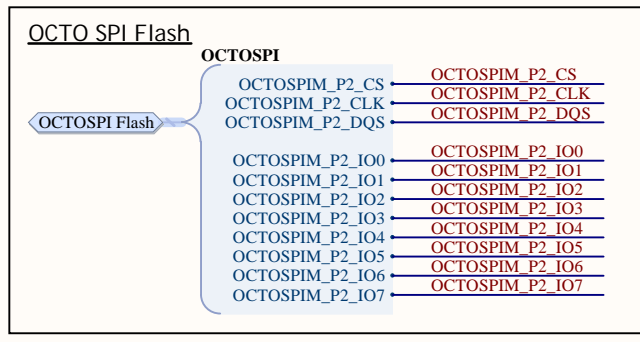

	U5 used (Default)		U6 used	
SB3	X	0R	[N/A]	
SB4	X	[N/A]	0R	
R8	10K		[N/A]	
R9	10K		10K	
R10	10K		10K	
R12	[N/A]		10K	
U6	[N/A]		fitted	
U5	fitted		[N/A]	
SB38	0R		[N/A]	
SB39	[N/A]		0R	

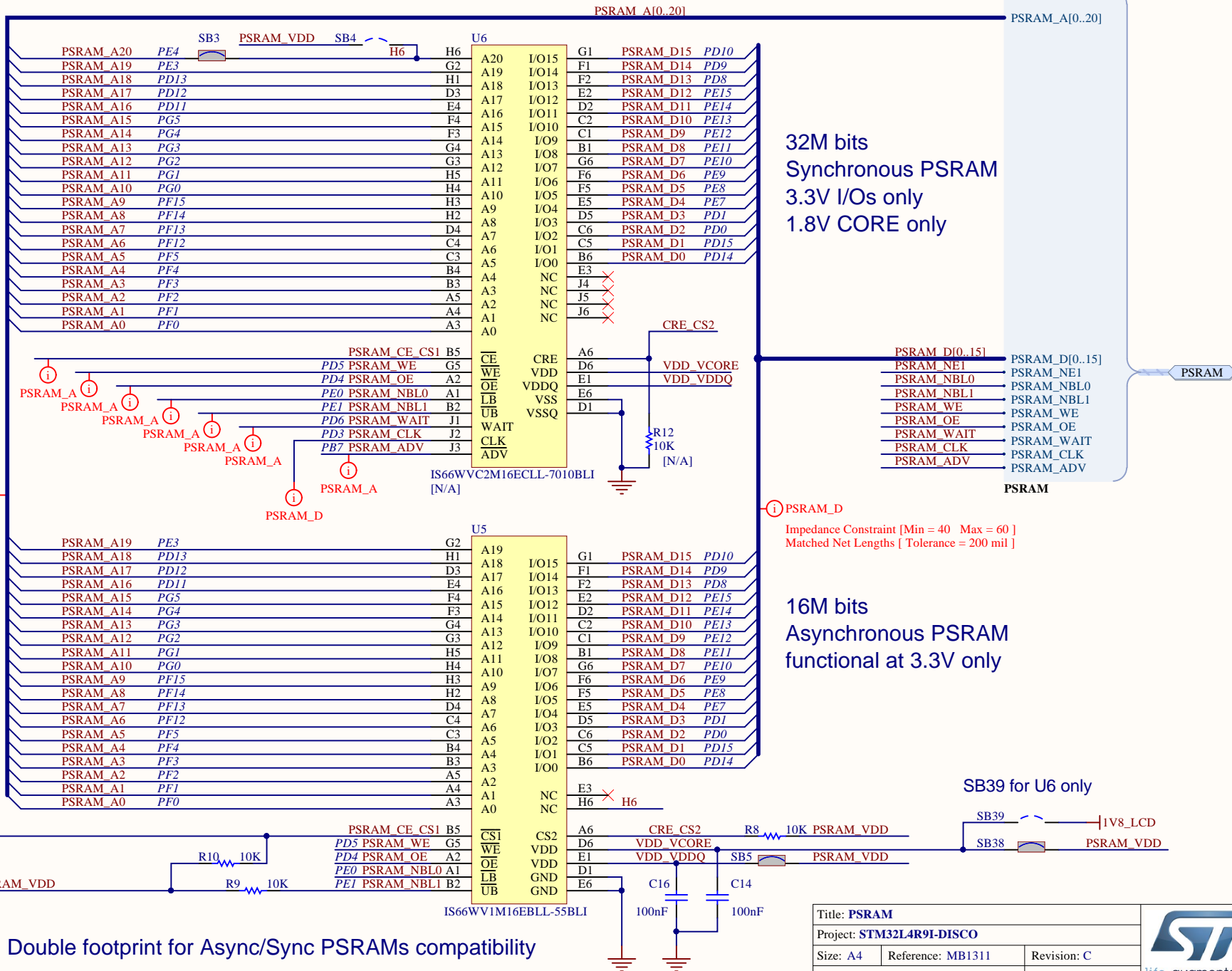

PSRAM\_A (i)  
Impedance Constraint [Min = 40 Max = 60 ]  
Matched Net Lengths [ Tolerance = 200 mil ]

PSRAM\_D (i)  
Impedance Constraint [Min = 40 Max = 60 ]  
Matched Net Lengths [ Tolerance = 200 mil ]

Double footprint for Async/Sync PSRAMs compatibility

## CAMERA is exclusive with some STMod+ , PMOD and ARDUINO signals

CAUTION : Following DCMI signals are multiplexed with other functions. In case CAMERA module is plugged, take care that the corresponding features are disconnected or well configured :

DCMI\_D0 : STMod+\_INT  
 DCMI\_D1 : DFDATIN3 (STMod+)  
 DCMI\_D4 : PSRAM\_A20 (only in case of U6 PSRAM is used)  
 DCMI\_D6 : STMod+\_PWM  
 DCMI\_D7 : STMod+\_RESET  
 DCMI\_HSYNC/DE : STMod+\_ADC and ARD\_D7

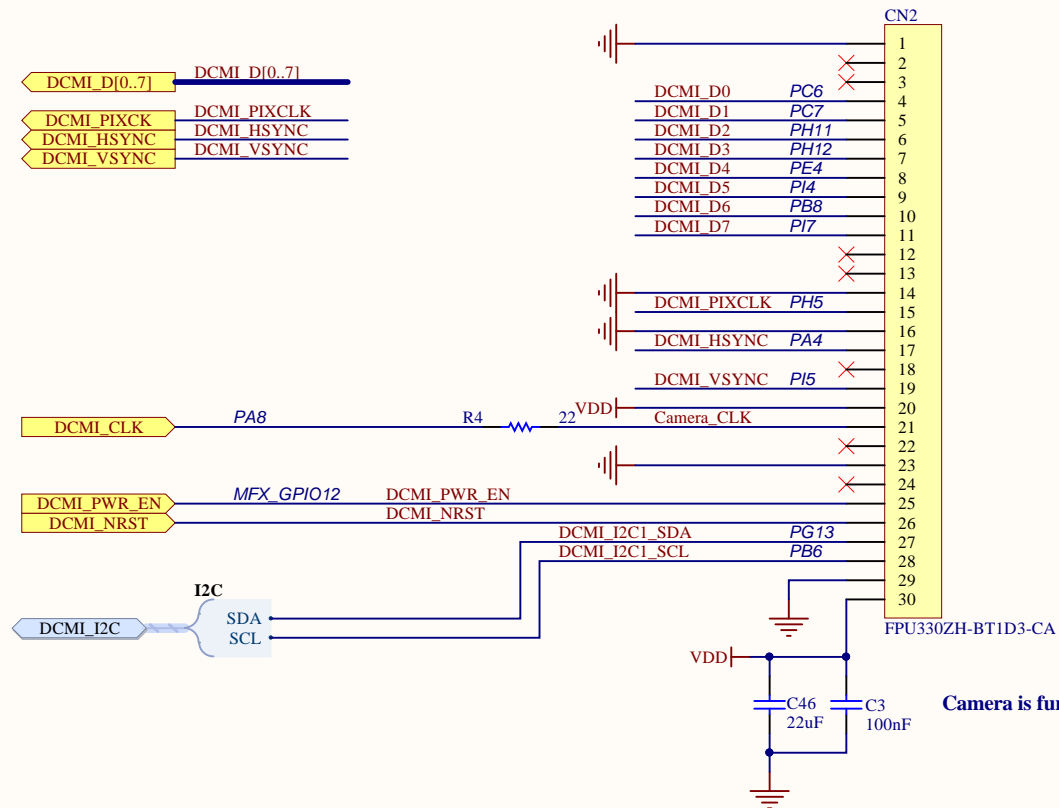

CAUTION : Following STMod+/PMOD signals are multiplexed or shared with other functions. In case STMod+/PMOD module is plugged, take care that the corresponding features are disconnected or well configured :

(\*)  
 STMOD+/PMOD USART3\_TX (PB10) may also use DSL\_USART\_TX option  
 STMOD+/PMOD SPI2\_MOSIp (PB15) shared with ARD\_D11 and DSL\_SPI2\_MOSI option  
 STMOD+/PMOD SPI2\_MISOOp (PB14) shared with ARD\_D12 and DSL\_SPI2\_DCX option  
 STMOD+/PMOD SPI2\_SCK (PB13) shared with ARD\_D13 and DSL\_SPI2\_SCK option  
 STMOD+ I2C3\_SCL (PG7) shared with ARD\_D15 (I2C3\_SCL)  
 STMOD+ I2C3\_SDA (PG8) shared with ARD\_D14 (I2C3\_SDA)

## STMod+

(\*)  
 STMOD+ INT (PC6) in conflict with DCML\_D0 (Camera)  
 STMOD+ RESET (PI7) in conflict with DCML\_D7 (Camera)  
 STMOD+ ADC (PA4) in conflict with ARD\_D7 and DCML\_HSYNC (Camera)  
 STMOD+ PWM (PA5) in conflict with ARD\_A5  
 STMOD+ DFDATIN1 (PB12) in conflict with MEMS microphones (use SB1 in audio page)  
 STMOD+ DF\_CKOUT (PC2) in conflict with MEMS microphones  
 DFDATIN3 (PC7) in conflict with DCML\_D1 (Camera)

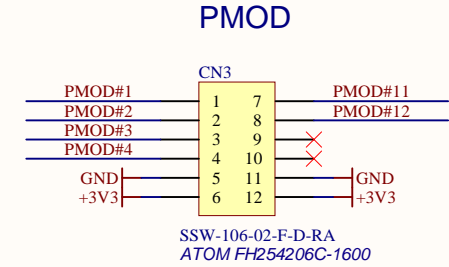
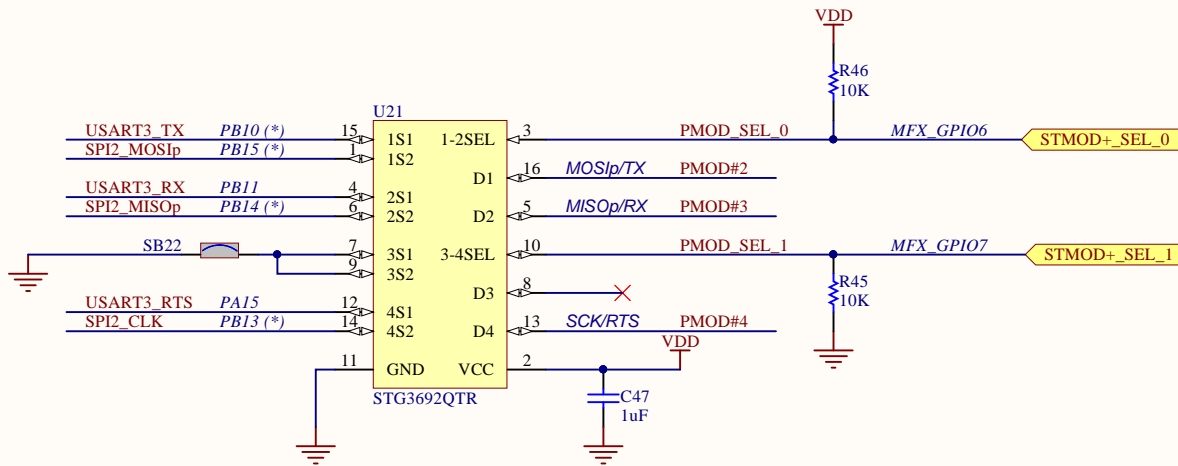
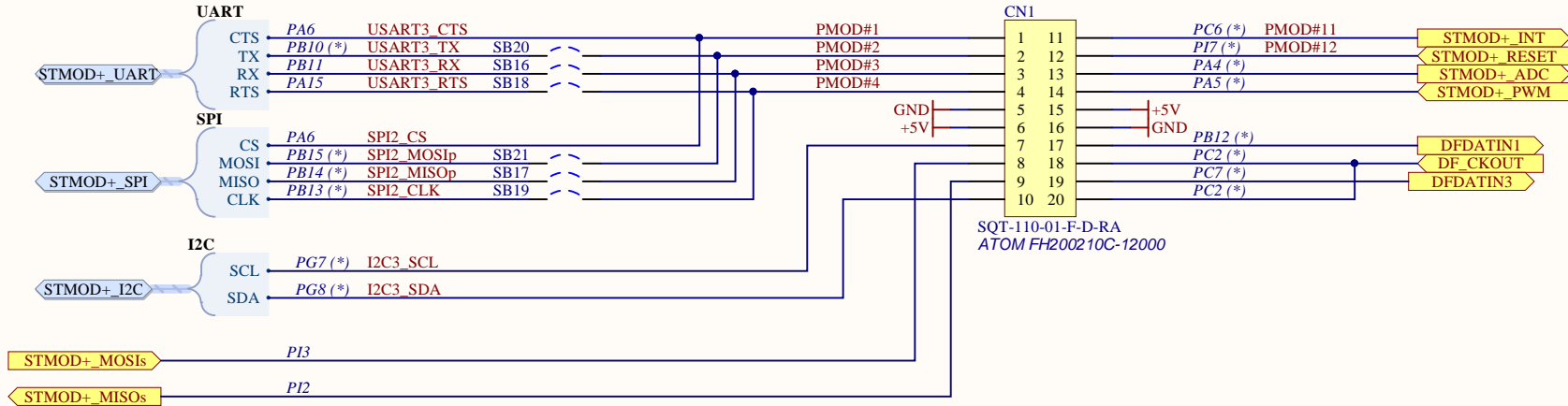

	SPI	UART/SPI	UART
STMOD+_SEL_0	0	1 (*)	1
STMOD+_SEL_1	0	0 (*)	1
PMOD#1 (PA6)	CS	CS	CTS
PMOD#2	MOSIp	TX	TX
PMOD#3	MISOOp	RX	RX
PMOD#4	SCK	SCK	RTS

(\*) default configuration to support MikroBus modules using MB1280 fan-out board

Title: <b>STMOD+ Interface</b>		
Project: <b>STM32L4R9I-DISCO</b>		
Size: A4	Reference: MB1311	Revision: C
Date: 28/08/2017	Sheet: 13 of 14	



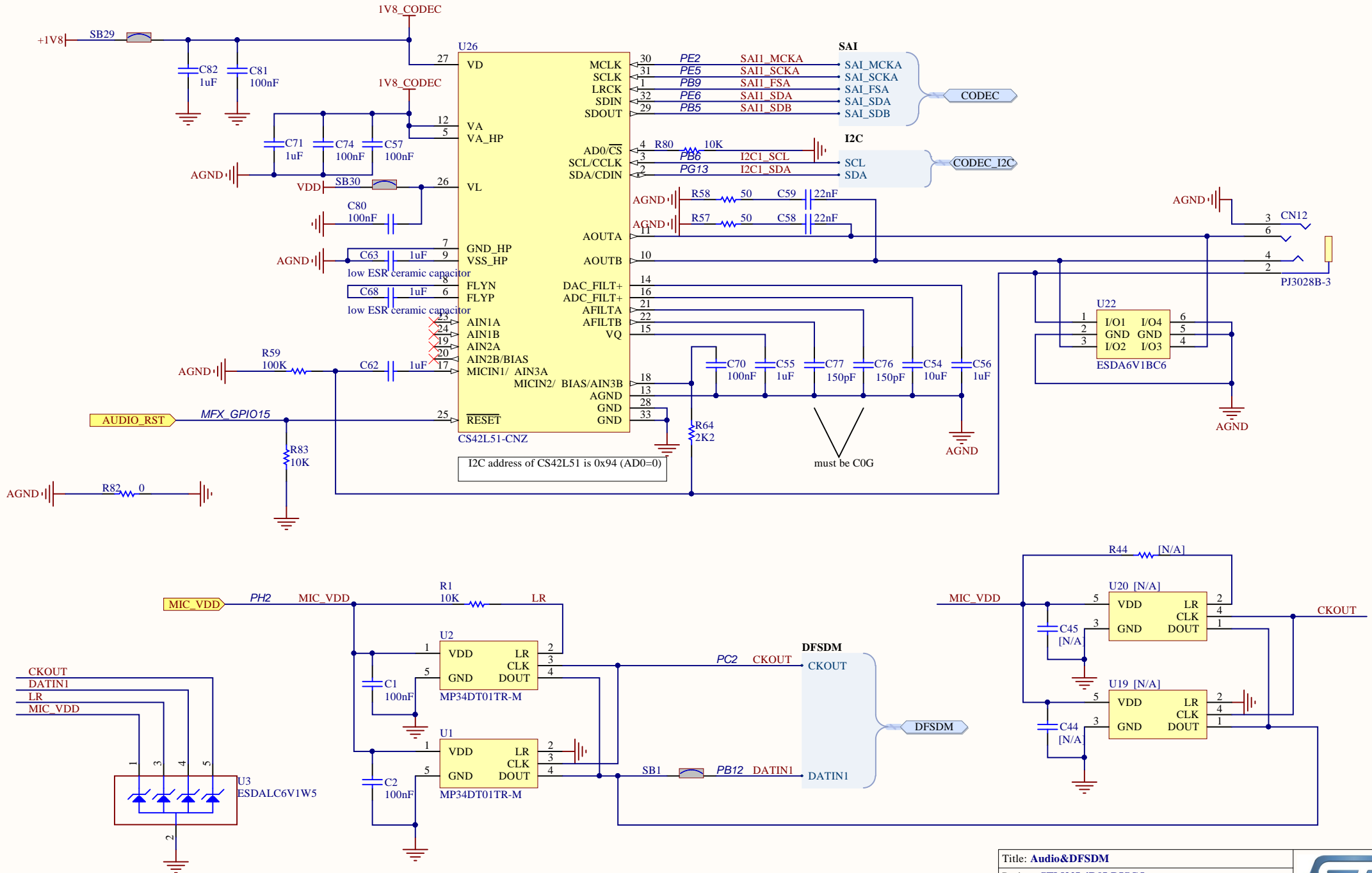

Title: Audio&DFSDM		
Project: STM32L491-DISCO		
Size: A4	Reference: MB1311	Revision: C
Date: 28/08/2017	Sheet: 14 of 14	

